

# Managing Power Line Hazards

Copyright © 1996 Construction Safety Council  
4415 West Harrison Street, Suite 407, Hillside, Illinois 60162  
Phone: (708) 449-0550 Fax: (708) 449-0369

*The mention of any product by brand name in no way constitutes an endorsement. Any products or materials not mentioned within this manual which may be considered acceptable as protective devices, equipment, or practices is not intentional and should not rule out their acceptability as employee or environmental protection.*

# Table of Contents

Chapter 1: Background .....	2
Chapter 2: Power Line Accidents .....	4
Chapter 3: Accident Sources .....	8
Chapter 4: Managing the Problem .....	10
Chapter 5: Underground Hazards .....	17
Chapter 6: Planning .....	18
Chapter 7: Dealing with Emergencies .....	21
Appendix A .....	25

# Chapter 1

## Tragic Losses

Every year, scores of workers lose their lives because of electrocutions caused by overhead and underground power lines. Thousands more sustain injuries from related burns which cause unimaginable pain. Electricity can actually cook your body's tissue from the inside out. The scars from such injuries won't go away, but with careful planning and prevention, many future tragedies can.

## The Human Cost

An operator of a truck-mounted crane was electrocuted when the boom load line contacted a 7200 volt overhead power line.

Workers installing a chain link fence directly under an overhead power line were electrocuted when one of the workers raised a long section of top rail and brought it into contact with the line.

The boom of a concrete pump contacted overhead power lines as it was guided over a pour. Both the nozzleman, and a fellow worker who attempted to assist him, received massive electrical shocks and burns.

As soon as an electrocution occurs, a worker's life and the lives of family and friends change forever. Depending on the severity of injury, the worker must often go through a long recovery which may include surgeries, physical and occupational therapy and counseling. This doesn't begin to address the psychological, social and financial burdens placed on the worker's family.

## Costs to the Contractor

Beyond the tragedy of human suffering from these needless accidents are the very sobering consequences to contractors. According to one major insurance carrier, the average claim cost for a power line electrocution is over \$550,000. Consider some of the direct and indirect costs of such an occurrence:

### Direct Costs

Medical costs up to limit of deductible  
Increased workers compensation premium  
Replacement of damaged equipment  
Liability lawsuits

### **Indirect Costs**

Reduced productivity/efficiency of crew(s)  
Costs to reschedule work  
Wages for supervision from accident  
Costs incurred by delays  
Cost of training/orienting new worker(s)  
Costs of overtime required because of accident  
Administrative hours devoted to accident  
Wages paid injured worker for time not worked  
Wages paid to other workers for time not worked  
Clean-up, repair, replacement and stand-by costs

Source: Levitt & Samelson, 1993

Survival in the competitive business of construction means a full appreciation for the economic toll of any accident, regardless of severity. When an injury occurs, your crew discontinues its work and is slow to resume it. Staff hours are devoted to investigation and follow-up. Your company is more closely scrutinized when it purchases insurance. The insurance you do purchase is more expensive. Your company is less competitive.

## Chapter 2

### Power Line Accidents

How and why do power line contacts occur? Approximately 500 power line cases were reported to the Occupational Safety and Health Administration (OSHA) between 1985 and 1994. A majority of these cases resulted in the death of at least one worker. Some resulted in three or more workers receiving electrical burns and other injuries, requiring hospitalization.

The leading cause of the accidental contacts was heavy equipment, (cranes, drill rigs, backhoes, etc.) Contacts by long-handled tools, (bull floats, etc.), items carried by workers and metal ladders used in proximity to overhead lines also accounted for a significant number of cases, (see Figure 1).

Figure 1: Power Line Contacts - U.S.

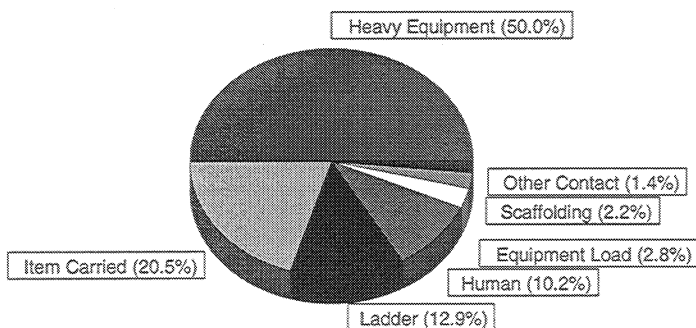

Additional high risk equipment and operations in which accidental power line contacts have frequently occurred include:

- Dump trucks
- Aerial Lifts
- Forklifts
- Scaffolding (both built-up and suspended)
- Positioning of workers in proximity to lines
- Materials handling and storage operations

OSHA’s investigations identified four trade contractors which employ the largest segment of at-risk workers:

- Roofing, siding and sheetmetal contractors (9.3%)
- Tree trimming contractors (8.5%)
- Water, sewer, pipeline and communication contractors (7.9%)
- Painting contractors (7.3%)

Over 90 percent of the power line contacts reported to OSHA involved overhead “distribution” lines, the same lines that run through most of our neighborhoods and, very frequently, on our job sites. “Service drops” running from poles to utility customers and “high power transmission lines” running from generating stations to substations accounted for seven percent. Approximately two percent involved buried cables.

Younger workers, between the ages of 20 and 35, suffered more than half of all the deaths and serious injuries reported (Figure 2)

## Figure 2: Injuries/Fatalities

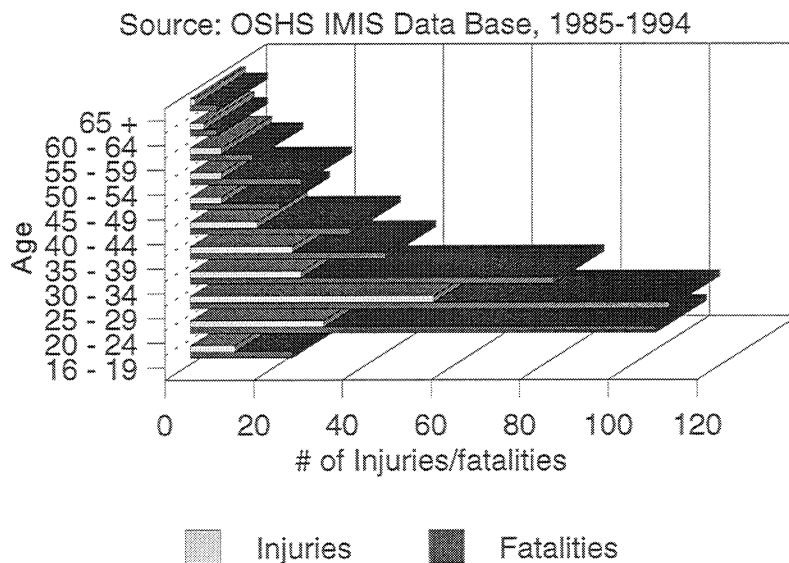

The root cause of reported accidents isn’t always clear. Many investigations conclude that workers just didn’t pay attention or didn’t take the hazard posed by the power lines seriously. We’ve all grown up around power lines and frequently do take them for granted. One common thread in most power line cases is clear however: workers, and all too often their supervisors, have an insufficient understanding of the hazards posed by overhead power lines. Many operate under some false assumptions...

Myth #1 “Overhead power lines don’t carry enough power to hurt you”

Reality: Overhead power lines carry voltages ranging from 120 to 750,000 volts. For an electrocution to occur, a path to ground must be created for the current. If your body touches a power source, the electricity will attempt to travel through your body, seeking ground or another power source with a different electrical potential. Because of the resistance in our bodies, the path taken by the current heats up and burns the body tissue inside us. Electricity leaves the body violently through that portion in contact with ground or a further path to ground, often leaving an “exit wound”.

Myth #2 “Overhead power lines are mostly insulated”

Reality: Overhead power lines are not “mostly insulated” Any covering you see on an overhead line is generally there for weather protection, not insulation. If you touch a power line, covered or bare, you could die.

Myth #3 “You have to contact an overhead power line to sustain injury.”

Reality: Electricity can arc over to an object. Although an arc’s initial striking distance isn’t appreciable, “brushing” up against a line with a conductive object, or simply having it within inches of the line and then backing it away can draw an arc out to several feet before it is extinguished. Your body doesn’t require sustained contact with a current source to suffer an injury.

Electrical injuries are caused by electricity and heat. When an electrical current passes through the body, a worker will feel a tingle from 0.5 to 1.0 milliamps (mA). At levels between 11 and 16 mA, the worker can’t let go. At 60 mA, the heart can stop. It is estimated that muscle damage due to electrocution occurs at levels of 1,500 mA and greater, (Table 1).

<u>Response</u>	<u>Threshold Current</u>
Perception	1.0 mA (M)
	0.5 mA (F)
Let-go	16 mA (M)
	11 mA (F)
Ventricular Fibrillation	60 mA (M,F)
Muscle Damage	1,500 mA (est.)(M,F)

M = male, F = female  
Source: Lee, Gottlieb and Krizek.

Depending on the current levels and length of exposure, the effects of heat generated by the electricity will vary. If the current is high enough, temperatures exceeding 1,800 degrees Fahrenheit can be generated. At this temperature, skin can vaporize instantly.

Whatever the reasons for power line accidents, a construction company's responsibility to ensure that its workers are trained in recognizing and avoiding the hazard is a matter of law. The following pages will enable managers to meet that important training requirement and explore a detailed approach to implementing a Power Line Hazard Awareness Program.



# Chapter 3

## Accident Sources

### Cranes

The most common types of equipment involved in power line-related fatalities between 1985 and 1994 were cranes. When a contact occurs, the crane almost always hits the overhead line with its boom or load line. The resulting injury depends on the type of crane involved.

Cranes used on construction work sites fall with two general categories, mobile cranes and boom trucks. When a mobile crane is involved, the rigger or ground worker is most frequently injured. When a boom truck is involved, it is most frequently the operator. Equipment design is the reason for the difference.

Boom trucks designed with controls mounted on the truck chassis and those equipped with pendant controls place the operator in direct contact with the ground. If a power line contact occurs, the operator is likely to sustain an electrocution injury. Some manufacturers offer boom truck designs which place the operator on an elevated platform, isolated from the ground. Others incorporate pendant controls activated by radio frequency or fiber-optics. It is important to note that even when cranes are equipped with radio or fiber-optic controls, an operator can still sustain injury as current can flow through the ground, creating a hazard.

Mobile cranes isolate the operator from the ground. With this type of equipment, it is most often the riggers and other personnel positioned on the ground near the equipment that are killed or injured. If the rigger is touching the load, the crane's load line, or even guiding the load with a tag line of nonconductive material that is moist or dirty, electricity can pass through those objects and the worker, seeking a path to ground.

### Other High Reach Equipment

Drilling rigs, Aerial Lifts, Backhoes and Concrete Pumps present a similar hazards when operated near overhead power lines. Raising and lowering the equipment and adjusting positions while portions of the equipment were aloft accounted for the majority of the injuries in this category.

### Ladders

The most common type of ladder involved in power line electrocutions is the metal extension ladder. A study conducted by the Consumer Product Safety Commission (CPSC) on ladder electrocutions found that of 54 ladder-related fatalities over an eight year period, all involved

metal ladders (CPSC, 1989). When ladder contacts occur, it is usually during raising, lowering or repositioning of the ladder while extended.

### **Material Handling and Storage**

A common problem on construction sites is insufficient space for storage. This frequently makes the areas under power lines tempting locations for staging and laydown operations. Such areas are frequently along right of ways and site access routes. It should be no surprise that most studies of power line accidents conclude that these locations pose the greatest risk.

# Chapter 4

## Managing the Problem

For any construction project to be successful, a plan must be followed from beginning to completion. To ensure optimum productivity, most contractors develop a “critical path” long before breaking ground. This is also a time for planning safety.

Any condition which can bring persons in contact with electricity is potentially dangerous. When the types of voltages carried by overhead power lines come into play, the danger is simply that much greater. Considering the kinds of variables that exist on most construction work sites - ever-changing site conditions, constant movement of materials and equipment, means for access, and human factors - the only reliable safeguard is distance.

## Line Clearance Distance

OSHA Requirements addressing power line hazards are fairly straight forward. They establish safe distances (buffer zones) from a power line which no object may enter from any direction. These “Line Clearance Distances” require that:

- ∩ For lines operating at 50 kilovolts (kV) or less, all objects must remain at least 10 feet away.
- ∩ For lines operating at voltages greater than 50 kV, the line clearance distance is increased by twice the length of the insulator or in accordance with the following formula:

$$10 \text{ feet} + (0.4 \text{ inches})(\# \text{ of kV over } 50 \text{ kV}) = \text{Line Clearance Distance}$$

<b>Table 2</b>	
<b>Line Clearance Distances for Power Lines</b>	
<b>Voltages</b>	<b>Distances from Power Lines</b>
≤ 50 kV	10 feet
200 kV	15 feet
350 kV	20 feet
500 kV	25 feet
650 kV	30 feet
800 kV	35 feet

In order to use the line clearance distance formula, a contractor must know the exact voltage of a power line. This can be done by calling the utility company that owns the line. It's difficult to determine for unqualified persons to determine the exact voltage of power lines simply by visual observation.

A good rule of thumb for deciding the line clearance distance is: If the line is 50 kV or less, keep all objects at least 10 feet away. For everything else, keep at least 35 feet away.

### **Safe Working Clearance**

The line clearance formula only computes the line clearance distance. It doesn't determine the safe working clearance - the closest distance that you can place a piece of equipment without crossing into the power line's buffer zone.

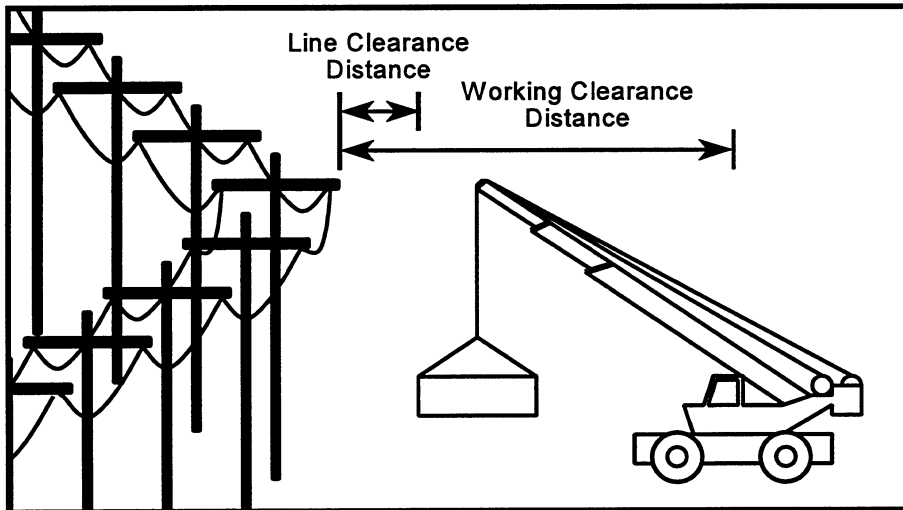

To make sure your equipment won't hit the power line, you must determine how close you can safely be to that line. How do you do this? By calculating the safe working clearance you need.

The working clearance is determined by adding the farthest reach distance of the equipment, half the horizontal distance of the widest object to be carried (if applicable) and the required line clearance for the closest power line. Then, measure from the center point of the equipment to the power line. If you end up on the equipment side of the line or directly underneath it, you're far enough away. If you pass underneath the power line before reaching the safe working clearance distance, you're too close and other measures will be necessary.

### Determining Safe Working Clearance

For example, let's say that you need to use a crane with 100 feet of horizontal reach (this includes all attachments to the boom) to move concrete form work (30 ft. by 20 ft.) at your job site. Nearby is an overhead power line that doesn't look anything like the distribution lines commonly seen in residential communities (i.e. less than 50 kV). So, the distances you need to add together to find the safe working clearance distance are:

100 feet	(length of the crane boom and all attachments)
15 feet	(half of the width of the concrete form work)
<u>+35 feet</u>	(line clearance for power lines with unknown voltages)
150 feet	safe working clearance

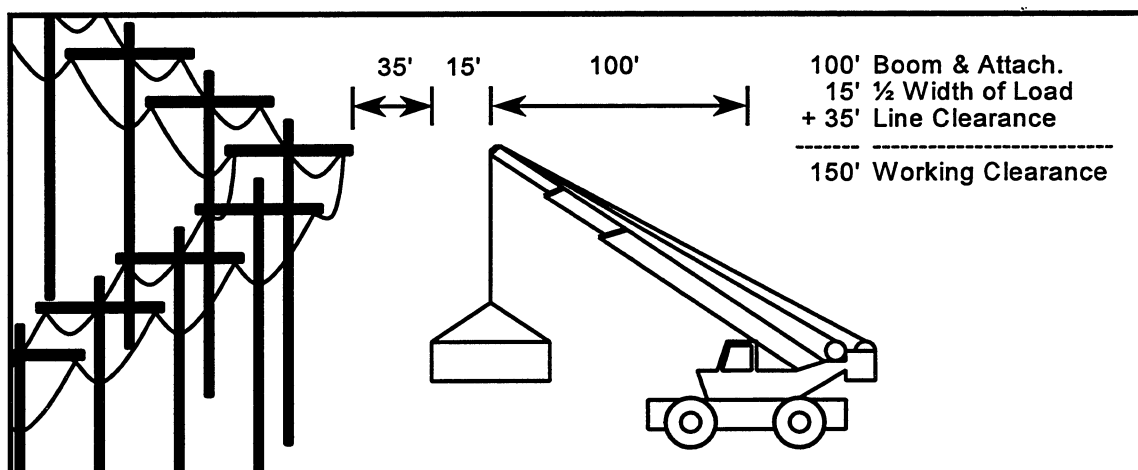

## Other Preventive Measures

What should be done if you find out that the equipment you're operating will be closer than the safe working clearance distance mentioned above? There are several options:

1. Have the power company de-energize the power line.
2. Have the power company move the power line beyond the safe working clearance distance.
3. Use barrier protection.
4. Use warning lines with flags.
5. Use an observer.

Let's look at each of these, in order of preference.

### De-energizing the Line

De-energizing and visibly grounding (usually by throwing a grounded chain across all conductors) the line should be the first option considered for protecting workers. By eliminating the source of the electrocution hazard, the danger is eliminated. There is one important point to keep in mind with this option. **Only power company personnel can de-energize a power line.** The contractor must ask the local utility to de-energize it. The utility may need several weeks to comply with your company's request, so the work should be appropriately planned.

### Moving the Line

Moving the line beyond the safe working clearance distance will reduce the hazard for the work crews near the line. However, like de-energizing the line, **only power company personnel can move a power line.** Only the utility that owns the line can move it. Again, the

utility may need several weeks to comply with the request. Work should be planned appropriately.

### **Barrier Protection**

Another option that your company may use is barrier protection. A barrier prevents physical contact between the high-reaching equipment and the power line. It can be made of any material that is non-conductive and not attached to the high-reaching equipment. The most common type of barrier is the insulating sleeve which is attached directly to the power line. Workers have been electrocuted when insulating sleeves have failed and the equipment they were working with became electrified.

If insulating sleeves are used, they can only be installed by power company personnel. Also, the sleeves must be appropriate for the type of work being performed. Most important: even with a insulating sleeves, you may not work any closer than the required clearance distance.

On many projects, power lines cross over temporary and permanent roads. Even though work may not be done around these lines, contacts can occur as equipment passes under them. To address this problem, your employer can use physical barriers called “goal posts” or “rider posts.” This type of barrier requires equipment operators to lower their equipment below a physical barrier placed under the power line. This barrier is an active reminder of the presence of overhead electrical line.

### **Warning Lines with Flags**

Using warning lines with flags is a way to visibly show where a power line’s buffer zone is located. This option requires the installation of flagged warning lines to the side and below the power line. The warning line must be made of non-conductive materials. When an equipment operator moves near the power line, a warning line will be available to mark the line clearance distance. The warning lines should not be attached to the utility line or pole. Placement of the warning lines can be achieved with the use of wooden poles. Remember, this system doesn’t allow you to work any closer than the line clearance distance.

### **Using an Observer**

The designated observer is assigned to monitor the distance between the high-reaching equipment and the power line. If the equipment nears the power line’s clearance distance, the observer warns the equipment operator. For this to work, the observer must be able to accurately judge the distance between an energized power line and the high-reaching equipment. This is very difficult because of limited visual perception.

When using an observer the contractor should do the following:

- Position the observer so that he has a clear view down the length of the overhead power line. This will usually be below the line but to one side of the high-reaching equipment for horizontal clearance, and off to one side of the power line and equipment for vertical distance.
- Don't give the observer other responsibilities that may create distractions.
- For horizontal clearance, use caution tape to mark the ground with the appropriate distance from the power line. This is done so that the observer knows the exact location of the line clearance distance. For cranes, as the load approaches the caution tape, the observer will know that the boom tip is nearing the power line's buffer zone. It's important that the observer be aware of any additional or unused attachments to the crane boom. Such attachments may cause portions of the crane to project out beyond the location of the load line.

## **Protective Technologies**

Protective technologies available for high-reaching equipment are limited in use and application. Most are designed for cranes, though some may be used on other high-reaching equipment.

Available technologies include:

1. Proximity indicators
2. Boom-cage guards
3. Insulating links

Proximity devices are designed to warn the crane operator when any part of the boom is moved too close to an overhead line. It is possible to get false readings with these devices, so the contractor must be familiar with the limitations of the equipment. Additionally, even when this device is being used, the operator must maintain the proper clearance distance from the power lines. When using insulated links, the operator still cannot work closer to the power line than the line clearance distance.

Boom-cage guards are designed to provide an insulating standoff that shields the boom from the power line. If a power line contact occurs, it will prevent the boom from becoming energized, thus protecting all workers involved. The drawback of this technology is that it only protects portions of the boom covered by the cage-guard. It is still possible for contacts to occur on other parts of the boom, the load line and the load. When using a boom-cage guard, the operator cannot work closer to the power line than the line clearance distance.

Insulating links are used between the crane hook and the load. They are insulated linkages that connect the load line to the crane's lifting hook. If a power line contact occurs, the linkage is designed to prevent electricity from passing to the load. The entire structure of the crane, however, is not protected and will remain energized. Therefore, it is possible for the



rigger to be protected, but any worker near the crane body to be electrocuted from current passing through the ground. The operator can also be electrocuted when stepping down from the equipment. It's important that links are regularly inspected and properly maintained to avoid premature failure. An insulated link doesn't allow an operator to work closer to the line.



# Chapter 5

## Underground Hazards

Buried power lines, regardless of voltage, present a different kind of hazard to construction workers than over head power lines. Their locations aren't as easily identified. When injuries from underground power lines occur, they're most frequently received by those operating powered hand tools or in contact with digging machinery. Workers lives and millions of dollars in damaged utilities are lost every year - in most cases because someone simply didn't call.

### **Call before you dig.**

We've heard it before, and yet, despite the availability of local one-call systems and utility locating services throughout the Country, excavating all too frequently proceeds without taking this easy and inexpensive precaution.

In most states, a contractor must notify a locator at least 48 hours (two business days) in advance. The ultimate responsibility for any damaged underground utility rests with the contractor performing the work. If you have a suspicion, even after the locations of buried utilities have been determined, hand dig with extreme care. Many cables are buried side by side. If, after finding an underground cable, you're still unsure about the presence of additional cables continue to hand dig.

Underground locating equipment is commercially available. Contractors who do a lot of excavating often find the cost for such devices to be far less than repair of a damaged utility.

# Chapter 6

## Planning

After you have identified the power line hazards and developed ways to prevent electrocutions, you should put it into a written plan. The plan should be treated like any job safety analysis and cover:

- The power line hazards on the job site.
- Methods to eliminate or reduce those hazards.
- Worker training (content and verification).
- Assignment of responsibility for certain activities (e.g. observer for crane near line).
- Communication between contractors about power line hazards and control methods used on the job site.
- Emergency response.

## Survey

Before beginning any project, you must first survey your work area to find power lines at the job site. The important question to ask is, “where are the power lines on the job site?”.

### **“Where are the power lines on the job site?”**

With prints in hand, go to the work site and identify all of the overhead and underground power lines that may put you or your workers at risk. Consider any line to be live until proven otherwise. Ideally, this should be done several weeks before beginning your job. If you think you’ll need a local utility to de-energize, move or shield any lines, contact the company well in advance. Area one-call systems and affected utilities may need several days to locate underground lines. Don’t cut yourself short by waiting until the last minute.

## Identify

After finding all of the power lines at your site, identify the activities you’ll be doing that may put you or your workers at risk. Ask yourself, “what will our company be doing that may result in a power line contact?”.

### **“What will our company be doing that may result in a power line contact?”**

List the activities that you believe will place any worker or piece of equipment inside the buffer zone of an overhead power line. Remember, high-risk equipment and activities include:

Cranes (mobile or truck mounted)  
Drilling rigs  
Backhoes  
Long-handled tools  
Other tools/high-reaching equipment

Aerial Lifts  
Dump trucks  
Ladders (especially metal)  
Building materials (conductive)  
Material Handling & Storage

Power lines over adjacent right-of ways and access roads can also present a contact risk. Look at the highest projections of the mobile equipment you'll use on your site. If it looks like a piece of equipment will cross into the buffer zone of a line, you'll need to prevent this from happening. Pay special attention to dump trucks. If the bed of a truck is not completely down when driving away, it can easily contact an overhead line.

If you're digging, find out how much advance notice the local one-call service needs and if the utilities in your area are members (many one-call systems do not have all utilities as members even though most states require that buried utilities be located).

## **Eliminate or Reduce**

After identifying the power lines and high-risk activities on your job site, you must determine how to eliminate or reduce the risk of electrocution. The question to ask is, "how can the power line electrocution hazard be eliminated or reduced?"

### **“How can the power line electrocution hazard be eliminated or reduced?”**

Can you change the activity to eliminate the hazard? If the activity will cross into the buffer zone of a power line, can the activity be moved to a safer location? If not, can the way the job is done be changed? Can non-conductive tools or tools that don't require long attachments be used? Remember, even with non-conductive tools, you will still need to maintain the minimum clearance distance.

Can the power company de-energize or move the line? By de-energizing or moving the line, the risk of electrocution can be significantly reduced. With a de-energized line, you'll need to insure that the disconnected line is visibly grounded and that the utility meets you at the site to identify the de-energized section. Additionally, the utility must meet with you before re-energizing the line. When a line is moved you need to insure that the location of the work activity doesn't change and expose workers to danger.

Your options for eliminating or reducing the hazard are:

- Move the activity.
- Change the activity.

- Have the utility de-energize the power line.
- Have the utility move the power line.

## **Control**

Your first choice is to eliminate or reduce the hazard. If this is not possible, then steps to control hazards must be taken. The question to ask is, “what can be done to control conditions to prevent contact with a line?”

### **“What can be done to control conditions prevent contact with the line?”**

Controls can take many forms. If you’re using a crane or other high-reaching equipment, you may be able to use an observer and have insulating sleeves installed by the utility company.

Your control options include:

- Use barrier protection.
- If using high-reaching equipment, use an observer.
- Use warning lines with flags.
- Use non-conductive ladders and tools.
- Protective technologies, knowing their limitations.

Always maintain your minimum safe clearance distance from the power line.

Appendix A of this booklet provides pre-planning checklist to assist you in evaluating the most common overhead and underground power line hazards.

# Chapter 7

## Dealing With Emergencies

### What to Do If You Hit a Line

Even with the best efforts, power line contacts can still occur. Your response is critical. Let's examine the best response to two common emergency situations involving power lines.

#### Power Line Contact with a Worker Isolated

Power line contacts involving equipment such as mobile cranes and backhoes generally don't result in injuries to the equipment operator. Injuries and death are usually suffered by the rigger(s) or other workers standing near the equipment. The reason for fewer injuries to operators is equipment design. If a contact occurs, the operator is at the same potential as the equipment. With a boom-truck, however, the operator is usually in contact with the ground and receives the shock as current seeks its path to the ground.

When an operator is isolated in the equipment cab and contacts a line, he/she should remain reasonably still on the equipment until the line is de-energized by the power company. Under no circumstances, except for extreme cases such as fire, should the operator leave the equipment.

**If a power line contact occurs, stay on the equipment. Don't leave unless there is an extreme emergency.**

If the operator must leave the equipment, he/she must jump from the equipment and land with feet together. The operator must be very careful to not touch any part of the equipment when contacting the ground. If he/she touches the equipment and the ground at the same time, an electrocution injury can result.

The operator must then shuffle his/her feet in very small steps away from the energized equipment. After a power line contact, the current flows outward through the ground in a ripple pattern. Areas of high and low potential circle the energized equipment like ripples in a pond after a stone hits the surface. If the operator steps from an area of high potential to an area of low potential, electricity can flow through the operator's legs causing injury or death.

Other workers standing near the equipment should move away from the energized equipment in the same manner.

- If you must leave the equipment:**
- 1. Jump from the equipment.**
  - 2. Shuffle your feet with very small steps.**

Current flowing through the ground is also why other workers in the area of the energized equipment must always stay away. If they walk up to the equipment, they may be electrocuted. Fatality reports have documented the deaths of many workers who were not touching the energized equipment but simply standing nearby in areas of high and low potential.

Current can flow outward through the soil in a ripple pattern from the equipment in contact with a power line.

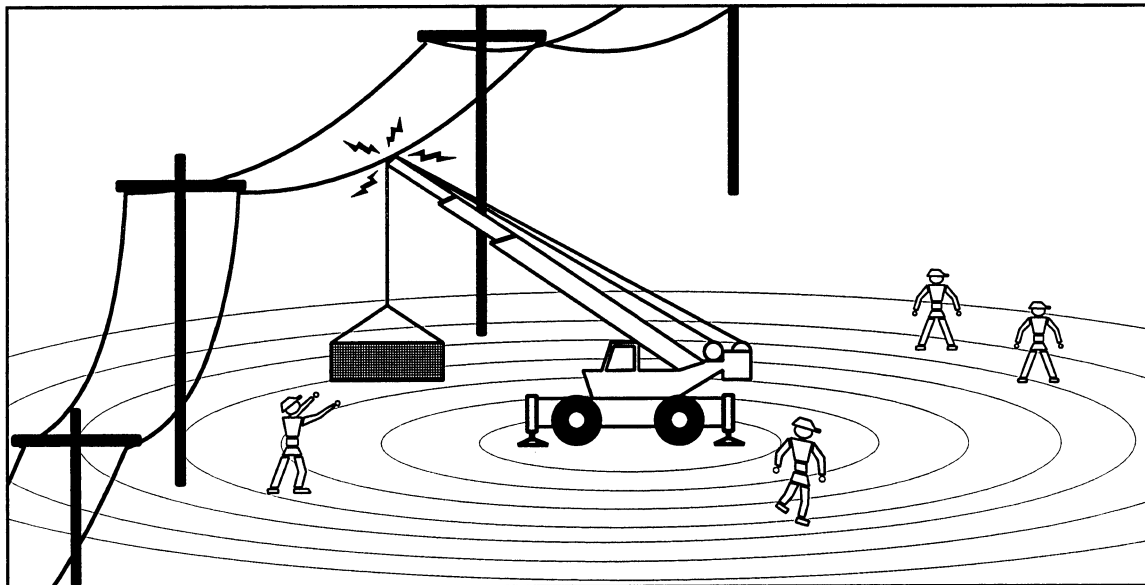

### **Power Line Contact with Worker Not Isolated**

A power line contact involving a worker who has sustained an electrocution directly from a source or ground is a very sobering experience. The only thing that co-workers can do is to wait until the power is turned off by the utility company. Under no circumstances should any



worker go near the injured employee. Remember, the power flowing through the ground could easily injure and kill you. Then, instead of one victim, there will be two. No matter what you think or feel, you can't go near the energized worker until you know the power is off. Remember, you can't be sure that the power is off just by looking at the victim. Rely only on emergency medical rescue professionals and/or utility company personnel to assist with a rescue.

## **Emergency Action Plan**

Among the predictable emergencies addressed in your company's emergency action plan, should be the methods you have identified to deal with accidental power line contacts. This aspect of your plan should include:

- Significant phone numbers (i.e. local hospital, power utility, etc.).
- Training of management and workers must receive.
- Guidelines for proper response to a power line contact.
- Roles and responsibilities of management and hourly workers.

## **Management and Worker Training**

Management and worker training should include the following areas:

- ˘ Identification of high-risk activities and equipment.
- ˘ Methods to eliminate/reduce contact risks.
- ˘ OSHA and other requirements.
- ˘ Overall emergency action plan and procedures .
- ˘ Power line contact emergency response.

Even though management and hourly workers may all be trained in the same areas, there is a difference in emphasis on specific sections depending on who is receiving the training. For example, management should receive more thorough training on hazard mitigation and the overall emergency plan. Workers should be more thoroughly trained in emergency response and job site specific requirements. Workers also need to know about the company's overall emergency plan in case it needs to be implemented.

## **After an Accident**

It's important that an investigation be performed immediately following an accident. Determine the root cause and make changes in your program to insure that the incident doesn't happen again. It is also important that you investigate "near miss" events that don't result in injuries or fatalities. These types of occurrences will identify areas in your program needing improvement.

## **Summary**

In this chapter, you learned about emergency planning. This involves developing an emergency contact list, proper training, and establishment of general and job site specific response guidelines. Finally, the importance of an accident investigation and early return to work were discussed.

# Appendix A

The following Pre-Planning Checklists are designed to offer a format for assessing risks and identifying ways to reduce or eliminate power line hazards. The material presented below assumes a comprehension of the information contained in the accompanying "Managing Power Line Hazards" booklet.

## **Cranes - [crawler cranes, rubber-tired hydraulic cranes, truck-mounted cranes]**

1. Where are the overhead power lines on the job site?
2. Will any crane be placed closer than the safe working clearance distance from the line?
  - a. Safe working clearance distance = the closest you can place a crane to an overhead power line without the farthest reach of the equipment, including the load being carried, crossing over the line clearance distance.
  - b. If you are not sure if your equipment will be far enough away, use the following formula to calculate the safe working distance.

\_\_\_\_\_ ft. = Farthest horizontal reach of the crane including all attachments (jibs, etc.)

\_\_\_\_\_ ft. = 1/2 of the greatest horizontal dimension

\_\_\_\_\_ ft. = Overhead power line clearance distance (Use 10/35 rule or calculate exact distance using formula in standard. Note: To use formula in standard, the exact line voltage must be obtained from power utility.)

----- **(ADD NUMBERS LISTED ABOVE)**

\_\_\_\_\_ ft. = Safe Working Clearance Distance (TOTAL)

3. If the crane will be closer than the safe working clearance distance to the line, can the power line hazard be eliminated?
  - a. Can the crane be moved to some other location away from the power line?

- b. Can the operation be changed in some way to eliminate the need for a crane?
- c. Can the utility company de-energize the overhead power lines?

Always meet with the power utility prior to de-energizing the line so that they can visually identify for you what sections of the line are de-energized. Always arrange with the utility to have them contact you in person when they re-energize the line. Even if you are working near a line that appears to be de-energized and visibly grounded, but if you are not absolutely sure, contact the utility and meet with them on site to visually identify the de-energized sections.

- d. Can the utility company move the overhead power lines?

Only the power utility can move an overhead power line.

- 4. If the power line hazard can't be eliminated, what can be done to prevent a line contact?

- a. Can barrier protection be used?

With any form of barrier protection, the contractor should not allow any portion of the crane to move closer than the line clearance distance.

If insulated sleeves are used, only the power utility can install them.

If a physical barrier is used to prevent any part of the crane from contacting the power lines, the barrier cannot be attached to the power line or utility pole, and must be substantial enough for the crane being used.

- b. Can warning lines with flags be used?

The contractor may be able to use flagged warning lines to visually mark the horizontal or vertical line clearance distance. The warning lines can't be attached to the power line or utility poles.

- c. Can an observer be used?

When using an observer, the observer should be positioned so as to have a clear view of the overhead line and must not be given other responsibilities that may create distractions.

For horizontal clearances, the observer should mark off on the ground the line clearance distance with caution tape or other highly visible material. Therefore, if the load nears the caution tape, the observer knows that the crane's boom tip is also near the power line's clearance distance zone.

For vertical clearances, the observer should use some nearby visual marker to identify the line clearance distance. One might use flagged warning line not attached to the power lines or utility poles.

d. Can protective technologies be used?

**Insulated link:** This type of device is designed to provide an insulating barrier between the load and the load line. The link must be periodically inspected and properly maintained. If a power line contact occurs on the rigging or the load, the rigger will not be protected. If a power line contact occurs on the boom or any other part of the crane, the operator and any workers near the crane will be exposed to a potential electrocution. With this device the operator can't work closer than the line clearance distance to an overhead power line.

**Proximity device:** This device is designed to warn the operator when the crane boom moves too close to an overhead power line. It is possible to get false readings with it, so the operator must be familiar with the device's limitations. With this device the operator can't work closer than the line clearance distance to an overhead power line.

**Boom-cage guard:** This device is designed to provide an insulating barrier between the guard and the crane boom. It must be periodically inspected and properly maintained. The device will only provide protection for the area of the boom covered by the device. This device does not allow the operator to work closer than the line clearance distance to an overhead power line.

## 5. Common Hazards Involving Cranes

- a. **Material storage underneath overhead power lines:** The contractor must not allow any material storage underneath any overhead line. A good way to prevent this from occurring is to use caution tape to cordon-off all areas under overhead lines and use signage to communicate why the area cannot be entered by equipment.
- b. **Operators and ground workers forgetting presence of overhead line:** If a crane must be located where the possibility of a contact can occur, measures must be taken to continually remind the operator and ground workers of the line's presence, and to actively prevent a contact. This can be done through the use of warning lines with flags, using an observer or having insulating sleeves installed by the utility company. The best options, if these are possible, are to move the activity away from the line, de-energize the line or have it moved beyond the safe working clearance. Finally, with lifts that occurs near an energized line, there should be a pre-lift meeting with everyone involved so that all workers are aware of how the lifts will be conducted and reminded of the power line hazards present.

- c. Operators and ground workers believing that a line isn't energized Consider all overhead lines to be live until determined otherwise.

# Appendix B

This appendix has been included to offer more background on crisis management. All contractors should develop a crisis management strategy, because failure to plan is to plan for failure in your response to an emergencies.

## Crisis Management

The best time to plan for a crisis is before an incident occurs. Sounds obvious, but for many contractors, crisis management often consists of simply posting the fire department's phone number in the job site trailer. By developing a systematic approach to managing a crisis, you will reduce an emergency's impact on your company. Effective crisis management involves developing a response team, a crisis plan and identifying possible crisis scenarios.

## Crisis Management Team

Flexibility and division of labor are the main reasons for developing a crisis management team. The team will provide adaptability to the specific need of the emergency at hand. The makeup of the team will consist of many more people than may actually be used in an emergency, but you will be prepared in case the unthinkable happens.

Team members should include:

- *Team leader* -- to control the crisis in the quickest manner possible resulting in the least number of ramifications.
- *Spokesperson* -- to provide information about your crisis to reporters, customers and others.
- *Public relations person/firm* -- to develop what is communicated to the public.
- *Project management personnel* -- are directly or indirectly related to the job site involved in the accident. They will provide immediate control of the scene, accident documentation and communications with the immediate family of an injured worker.
- *Team secretary* -- to provide clerical and other needed support of the team.
- *Human resources representative* -- to provide information to company employees.
- *Financial council* -- to address financial concerns.
- *Legal council* -- to address legal concerns.
- *Government liaison* -- to provide communications with appropriate governmental entities (Reid, J.L., 1987).

## **Crisis Management Plan**

A crisis management plan will contain a number of important elements. The extent of your plan will depend on your company's size.

Your plan may include:

- 1) *Emergency contact list* -- a list of key people inside and outside the company including utility personnel.
- 2) *Employee contact list* -- a list of all employees in company (home #'s, pagers, etc.).
- 3) *Contact lists for your other audiences* - a list of other significant parties (clients, engineers, etc.)
- 4) *Current projects/teams* -- a list of current projects and associated information.
- 5) *Completed project data* -- a list of past projects and associated information.
- 6) *Pointers for spokesperson* -- guidelines for the spokesperson.
- 7) *Notifying the victim's family* -- procedures for notifying the victim's family.
- 8) *Safety history* -- a list of safety accomplishments of company.
- 9) *Company recognition/achievements* -- a list of recognition/achievements of company
- 10) *Media list/log sheets* -- a list of media contacts in your area and a way to track information given.
- 11) *Company fact sheet* -- a brief description of the company.
- 12) *Key employee biographies* -- a collection of key employee biographies.
- 13) *Contingency procedures* -- a list of emergency procedures for specific situations.
- 14) *Notifying employees of team formation* -- to insure appropriate people are contacted for crisis events.
- 15) *Emergency procedures card* -- to provide guidelines for workers in the event of an emergency. Who should be called and what workers should do (Reid, J. L., 1987).

## **Crisis Management Planning**

Crisis management planning is the process of identifying, determining the impact of and outlining your company's responses to probable emergencies. Scenarios to consider regarding power line accidents include:

- 1) *Worker injury/death* -- Issues to consider include:
  - a) Hospitalization of worker (Is the hospital to be used set up to handle electrical trauma?)
  - b) Communicating with worker/family (Does the worker/family speak English?)
  - c) OSHA investigation
  - d) Media response
  - e) Lawsuits
  - f) Counseling of co-workers



- 2) *Power outage from severed line* -- Issues to consider include:
  - a) Effect on local community (i.e. hospitals, radio/TV stations, phone system)
  - b) Media inquiries
  - c) OSHA inquiry
  - d) Lawsuits
  
- 3) *Explosion/fire occurred and job site in danger area* -- Issues to consider include:
  - a) Response of local authorities to scene
  - b) Media inquiries
  - c) OSHA inquiry
  - d) Effect on building owner/developer
  
- 4) *Damage to private property* -- Issues to consider include:
  - a) Exaggerated claims
  - b) Community groups
  - c) Effect on building owner/developer
  
- 5) *Injuries/death to public* -- Issues to consider include:
  - a) Media response
  - b) OSHA inquiry
  - c) Lawsuits
  
- 6) *Blocking of traffic* -- Issues to consider include:
  - a) Media response
  - b) Special equipment/personnel requirements

These are just a few of many scenarios which should be examined in developing an emergency action plan. By detailing how your company intends to respond to an emergency situation, needless aggravation and costly delays can be minimized. Once developed, your company can work to insure you'll never need to implement your plan. If the unthinkable does happen, however, you're ready.

# Figure 5: Power Line Contacts - U.S.

Source: OSHA IMIS Data Base, 1985-1994

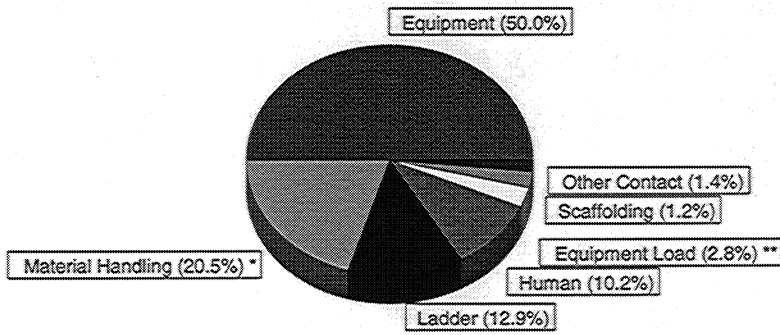

## Figure 4

Accident Distribution by Worker Function (Paques, 1993)

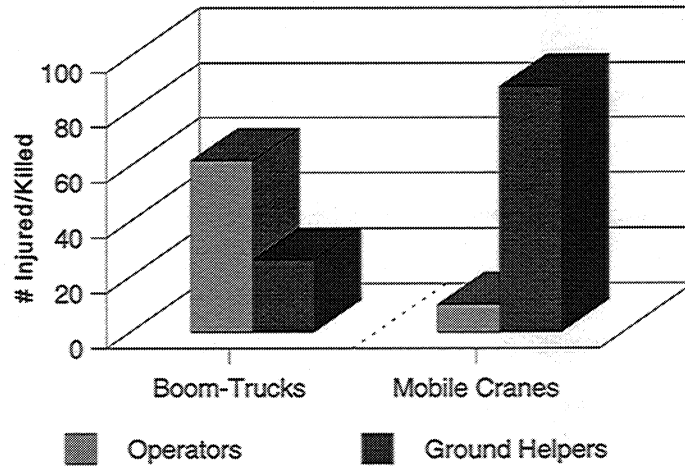

# Figure 2: Heavy Equipment Contacts

OSHA IMIS: 1985-1994

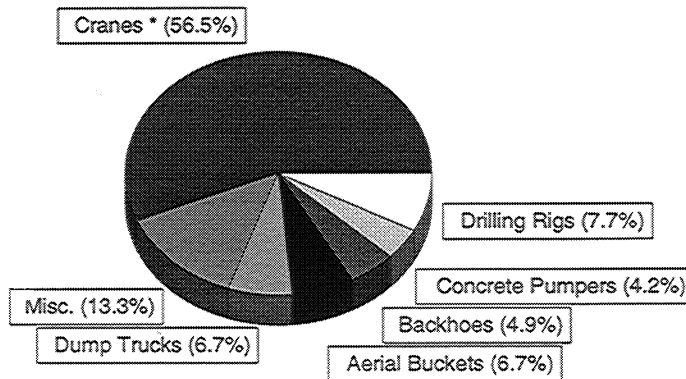

\* Cranes include: mobile cranes, boom-trucks and shovels

---

**Table 5: Impact of Experience Modifier on Workers' Compensation Insurance Premium**

Base Premium of a Contractor = **\$289,645.00**

<u>With an EMR of:</u>	<u>The Premium Cost to the Contractor is:</u>
<b>0.5</b>	<b>\$144,822.50</b>
<b>1.0</b>	<b>\$289,645.00</b>
<b>1.5</b>	<b>\$434,467.50</b>

Cost Difference Between an EMR of **0.5** and **1.5** is **\$289,645.00**.

---

---

**Table 4: Typical Workers' Compensation Premium for a General Contractor**

*General Contractor with \$5 Million in Work Volume*

<u>Classification</u>	<u>Payroll</u> <sup>1</sup>	<u>WC Rate</u> <sup>2</sup>	<u>Insurance Cost</u>
Roofing	300,000	39.95	119,850
Millwright	400,000	19.31	77,240
Steel Erection (not over two stories)	50,000	180.11	90,055
Clerical	200,000	0.39	780
Sales	<u>200,000</u>	0.86	<u>1,720</u>
Total	\$1,150,000		\$289,645

<sup>1</sup> Payroll excludes overtime premiums and fringe benefits.

<sup>2</sup> \$ per \$100 of insured payroll, using the 1995 Illinois rates.

---