

Module 10 : Differential Protection of Bus, Transformer and Generator

Lecture 38 : Bus Protection

Objectives

In this lecture, we will learn

- Importance of redundancy in bus protection.
- Different bus arrangements and their application like:
 - Single bus single breaker arrangement.
 - Single breaker double bus with bus tie.
 - Double bus double breaker arrangement.
 - Ring bus arrangement.
 - One and a half circuit breaker arrangement.
- Implementation of differential bus protection using high impedance bus differential relay.
- Non-linear percentage differential characteristics.

Introduction

Faults in a power system can be either apparatus faults or bus faults. Apparatus faults refer to faults in feeders, transformers, generators or motors. On the other hand bus is an external interconnection point for terminals of different apparatus. A bus fault is usually rare, but if and when it happens its consequences can be quite severe. It can lead to loss of multiple feeders or transmission lines and hence has a potential to create a large enough disturbance to induce transient instability. Even if it does not lead to transient instability, loss of load from an important substation can be quite high. Because of these reasons, bus rearrangement can have sufficient redundancy so that in case of a bus fault, an alternative bus automatically takes over the functions of the 'main bus'. Thus, the end user sees no disruption in service except during the fault interval. This can however involve significant costs, viz the cost of new bus bars and additional circuit breakers to configure a parallel arrangement. Hence, different bus configurations are used in practice – each one representing a different trade off between cost, flexibility and redundancy. In this lecture, we will discuss following bus arrangements: -

1. Single bus - single breaker
2. Single breaker - double bus with bus-tie
3. Double bus - double breaker
4. Ring bus arrangement
5. One - and - a - half circuit breaker arrangement

Differential protection discussed in lecture 3 is used for bus protection. If the algebraic sum of all apparatus currents is zero, then there is no fault on the bus. However, during bus fault, the apparatus current sums to the bus fault current.

Single Bus Single Breaker Arrangement

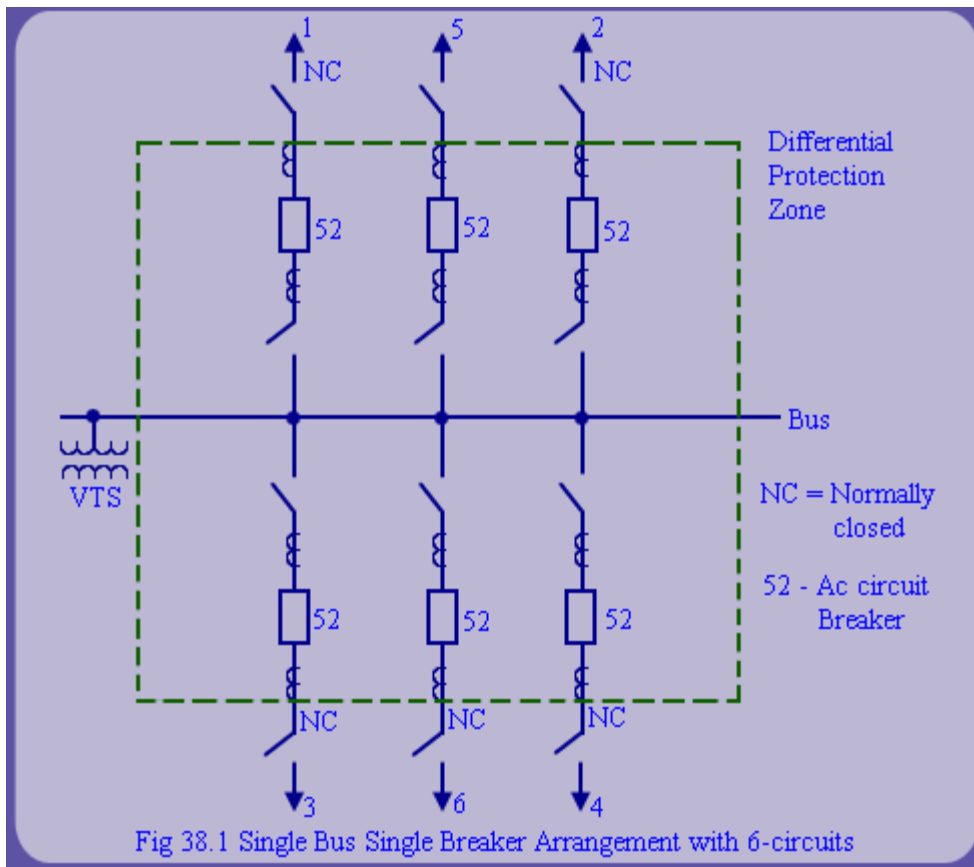

Fig 38.1 shows the single bus single breaker arrangement. In this particular example, there are six feeders connected to a bus. Each feeder has a CT to monitor feeder current while a single VT is used to measure bus voltage. The 'NC's are mechanical switches which are normally closed. During bus maintenance, these will have to be opened to guarantee safety to maintenance personnel.

In case of bus fault, all the breakers have to be opened to isolate the bus. In turn, it leads to severe disruption of service to loads. Hence, this scheme has minimum flexibility. However, it uses minimum number of circuit breakers, (one per feeder) and it also requires only one VT.

Hence, it is cheap and is used for non critical, low priority feeders where loss of service is not a prime consideration but low cost (investment) is.

Single Breaker Double Bus with Bus Tie

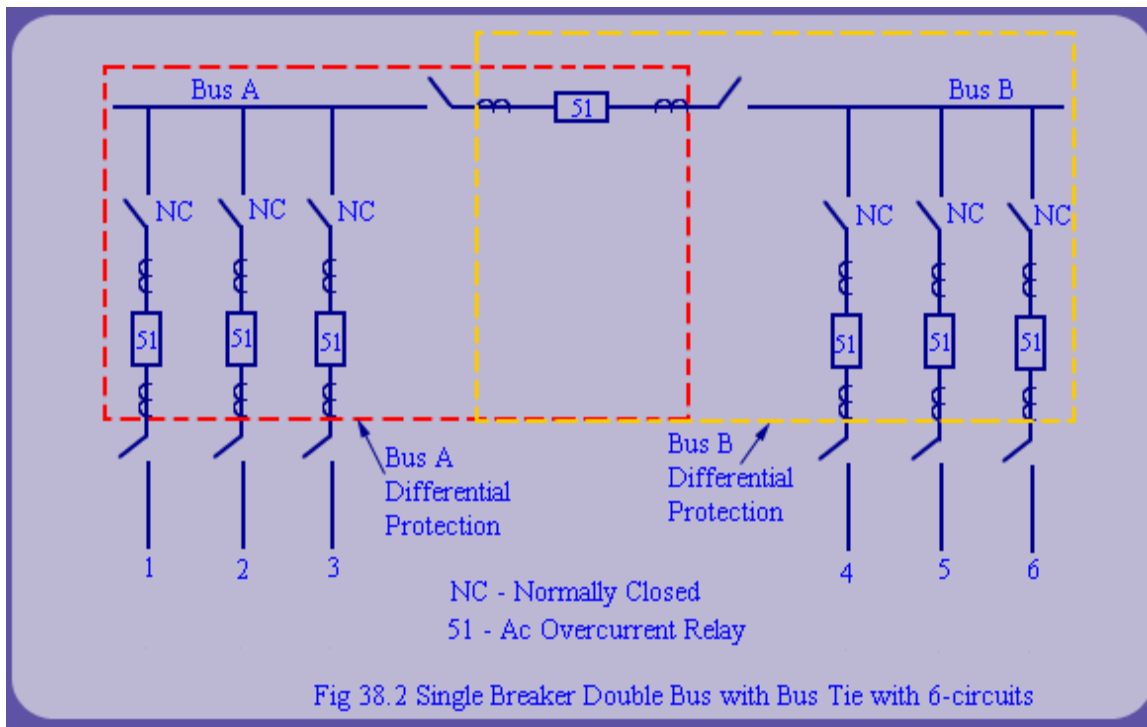

Fig 38.2 shows the arrangement.

This arrangement is used when

1. **Large number of circuits exists especially at lower voltage and industrial substation.**
2. **Substation is fed from two separate power supplies with one supply for each bus.**

If each bus has its own source, then bus coupler with overcurrent protection can be opened or closed. In case of loss of supply, 51 (AC time overcurrent relay) is closed. For each bus, there is a differential protection is provided. For a bus fault, we have to open all circuit breakers on bus along with 51T (trip breaker). Thus, bus fault leads to only partial loss of service. The arrangement requires two VTs. Hence, this scheme with addition of one bus bar and circuit breaker improves flexibility in comparison to the single bus single breaker scheme.

Double Bus Double Breaker Arrangement

Fig 38.3 shows a double bus, double breaker arrangement.

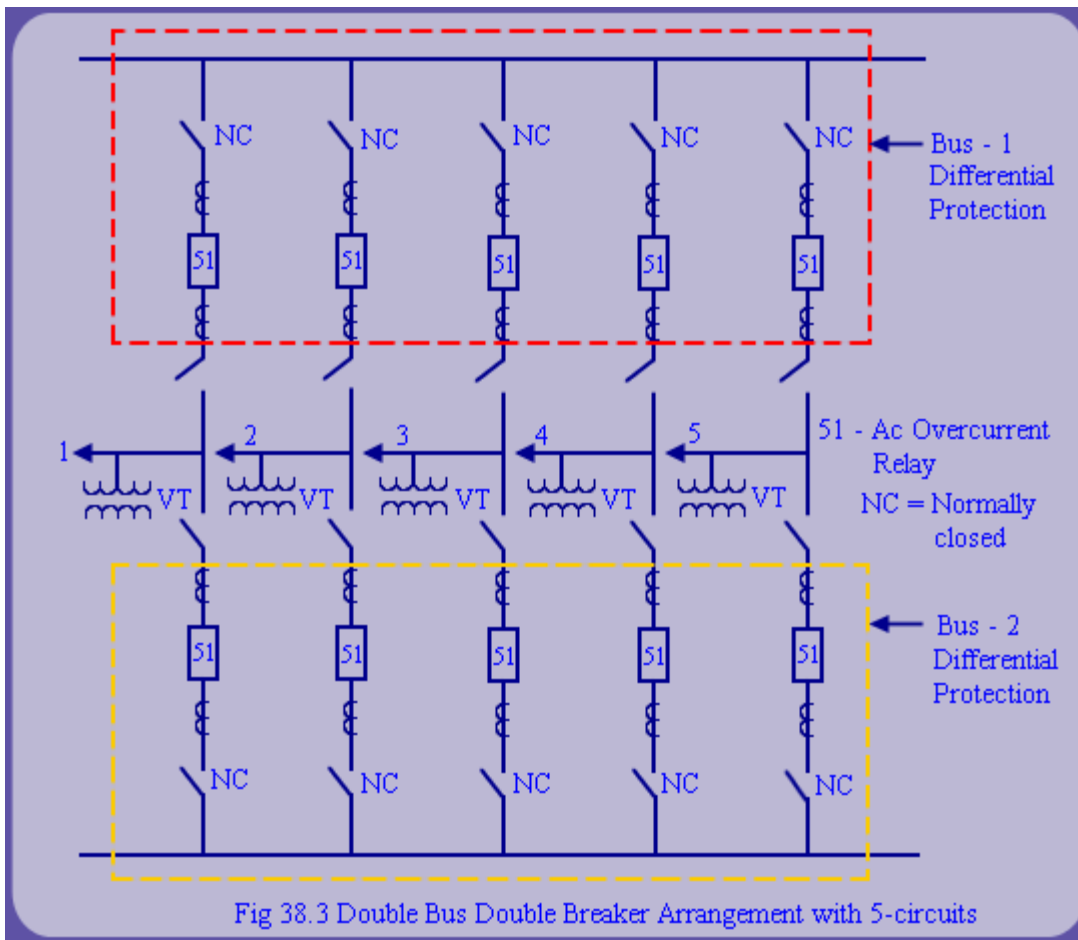

As shown in the fig 38.3, each feeder is connected to two buses which in normal operation mode are paralleled. Bus differential protection is provided for each bus. This scheme would be used typically at high voltages like 400kV. Distance protection of such voltage level has to be directional as fault in the primary line of Z2 of one of the relays cannot be left unattended for time required for Z2 operation. Hence, directional comparison scheme is required for which CCVT is used for communication. Hence, one CCVT per feeder would be used along with this scheme. In case of a bus fault (say on bus-1), the breakers connected to it will have to be opened. Subsequently, the system function then automatically switches to alternative bus (e.g. Bus 2) with no loss of service to load.

In case, if a feeder has to be isolated, both the breakers connected to it will have to be opened. For line (feeder) protection, to measure feeder current the CT contribution from both bus 1 and 2 have to be summed. i.e. corresponding CTs are paralleled. In case of a stuck breaker, local backup for breaker failure is to operate all the corresponding bus breakers. This bus arrangement provides maximum flexibility but it is also costly as two breakers per feeder are required.

Ring Bus Arrangement

Fig 38.4 shows a typical ring bus arrangement with four feeders.

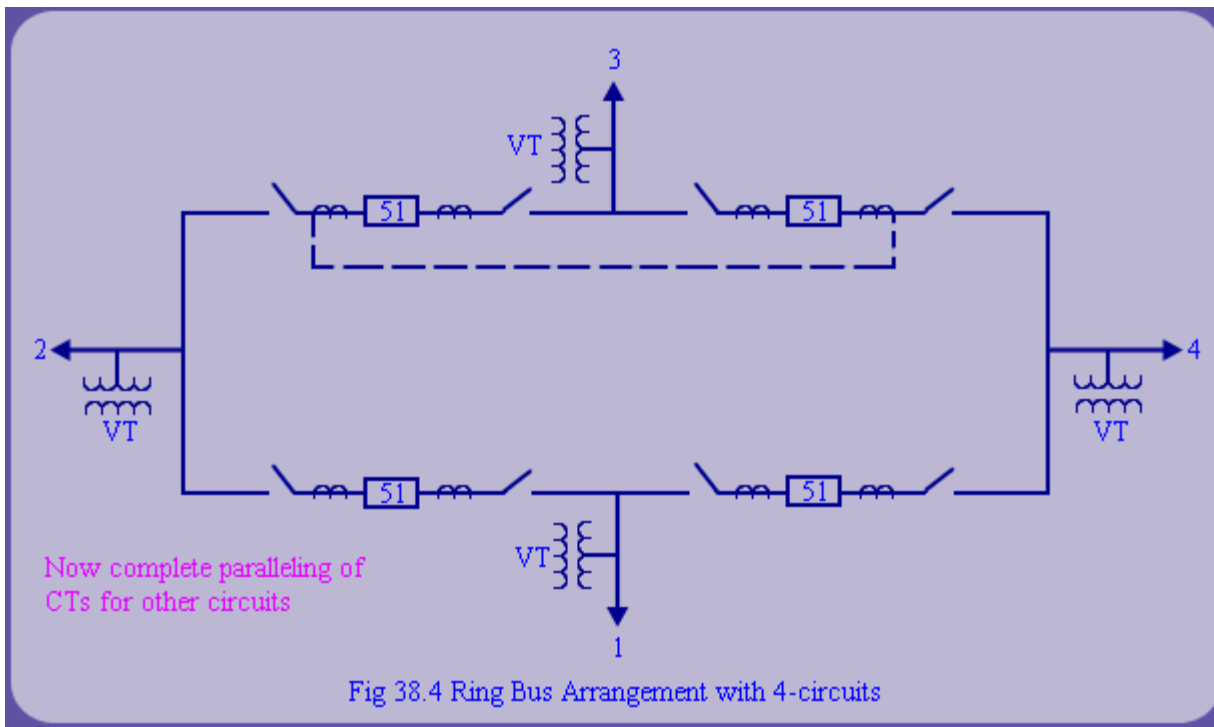

Again to isolate a feeder, say on a feeder fault, two adjacent breakers have to be operated. Similarly, feeder current is calculated by summing or paralleling the appropriate CTs. Each feeder requires its own VT. The arrangement requires one circuit breaker per feeder and hence it is less costly. This arrangement is popular because of low cost and high flexibility. As the bus section between the two breakers becomes a part of the line, separate bus protection is not applicable or required. i.e, the feeder protection also provides the functionality of bus bar protection.

One and a Half Circuit Breaker Arrangement

Fig 38.5 shows the one and a half circuit breaker arrangement.

It is so called because total number of breakers is 1.5 times the number of feeders. Fig 38.5 shows the arrangement with 4 feeders and 6 breakers. There are two buses, each one having its own bus differential protection. In case of a bus fault, all breakers connected to the bus will have to be opened. Automatically, the system operation moves to alternative bus without any further loss of service. Hence, this scheme also provides a high level of flexibility.

Now, consider the case of a stuck breaker say while clearing of feeder fault on L_1 . In case of a stuck breaker which is connected to the bus (shown in red in fig 38.5), the local breaker

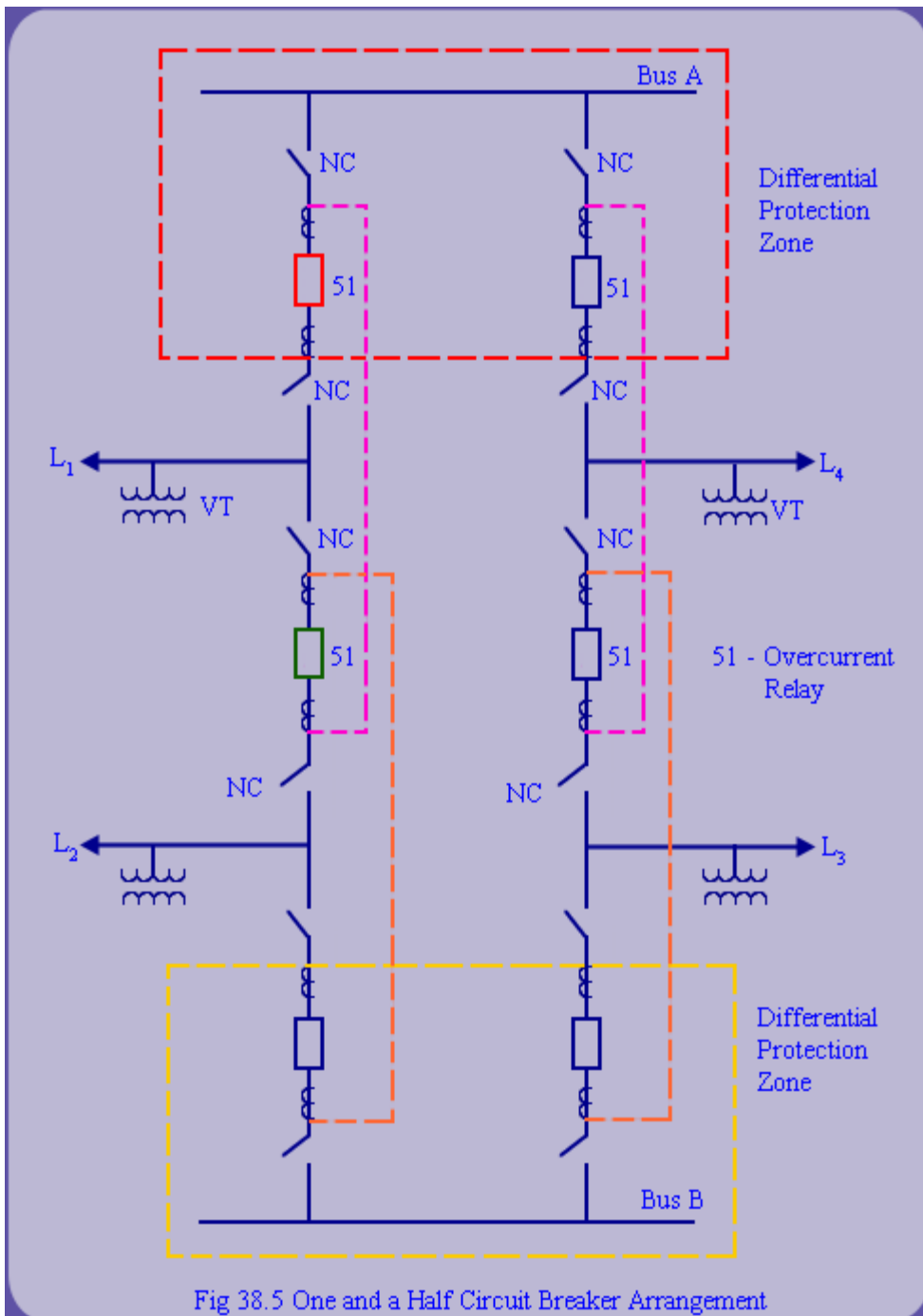

backup (LBB) is to open all the breakers on the bus. In the case of stuck central breaker (see green breaker) i.e. when the shared breaker is stuck, LBB consists of opening the adjacent breaker. In addition, a transfer trip signal is required to the breaker at the remote end of the feeder (L_2) connected to the stuck breaker.

Differential relay for bus bar protection can be implemented in one of the following three ways:

1. **Sample by sample comparison.**
2. **Comparison of current phasors.**
3. **High impedance bus differential relay.**

The main difficulty in bus differential protection is that significant differential current may appear due to saturation of CT on external fault. When a CT saturates, its secondary current is not scaled replica of primary current. Therefore, sum of CT secondary current is not equal to sum of primary currents even though primary CT currents sum to zero.

This causes a differential relay to operate on even external faults, leading to maloperation of bus protection scheme. This compromises security and is not acceptable. While the percentage differential can provide security against normal CT errors due to mismatch of CT turns ratio and magnetization current; it is not adequate to handle severe CT saturation problem. So the relevant questions to be asked now are:

- (1) **How was this problem handled in the past, i.e. in the era prior to numerical relays?**

(2) How do numerical relays cope with this problem?

High Impedance Bus Differential Relay

This approach has been the most successful with traditional electro mechanical and solid state relay. It is based upon the following ingenious and innovative thinking. If you cannot beat CT saturation, exploit it! In fact this is now a well accepted principle in theory of systematic innovation, also known as TRIZ (a Russian acronym), that one innovative way to problem solving is to exploit the harm:

"If you cannot undo the harm, stretch the harm to the extreme and then exploit it to your advantage".

Recall that when a CT core saturates, it behaves more like an air core device. The coupling between the primary and secondary winding is negligible. The impedance now offered by the CT as seen from the CT secondary terminals is very low and it equals the impedance of the CT secondary winding. The CT is no more a current source with high impedance shunt. Rather, it is a plain low impedance path. Thus, if we increase the impedance of the relay element which was to carry the differential current significantly, then sum of all the CT secondary currents (except for the saturated CT) will be diverted into the low impedance path of saturated CT's secondary. Therefore, differential current would be negligible and hence protection system will not operate (See fig 38.6). Thus, now saturation of CT itself is responsible for saving a false operation.

High Impedance Bus Differential Relay (contd..)

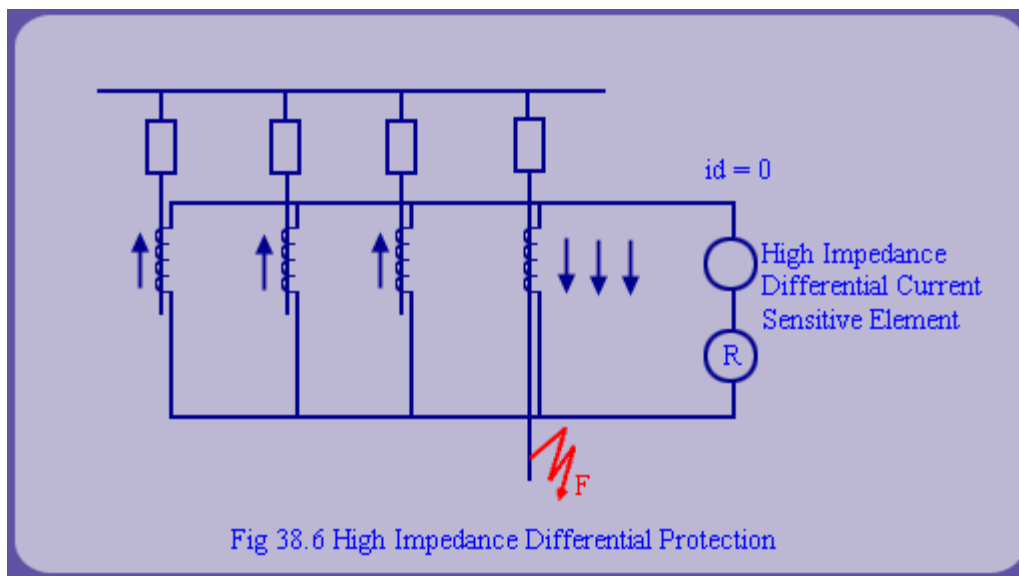

In contrast, numerical relays offer a low impedance path. Hence, this scheme of differential bus bar protection cannot be emulated with numerical relays. Therefore, with numerical relays the busbar protection has to be very fast. i.e preferably decision making has to be completed before the CT saturates. Recall that saturation of CT is primarily a consequence of DC offset current.

The time for CT core saturation also depends upon time constant (L/R) of transmission line. If the protection system could reach trip decision before the onset of CT core saturation, then it would be reliable. Hence, numerical relaying based bus bar protection is expected to operate in quarter of a cycle. Development of such protection scheme requires ingenuity because of the well known speed vs accuracy conflict.

Non linear % Differential Characteristics

If the CT core saturation factor could be discounted for, then we could use constant % differential characteristic for bus bar differential protection. We model a CT as scaled current source due to transformation ratio in parallel with magnetizing impedance (Norton's equivalent). However, the magnetizing impedance itself is nonlinear. It is large when CT core is not saturated and small when CT core is saturated. The current in this branch directly contributes to the differential current.

Non linear % Differential Characteristics (contd..)

This suggests that % differential characteristics should be modified to have higher slopes to take care of CT saturation. A fast protection

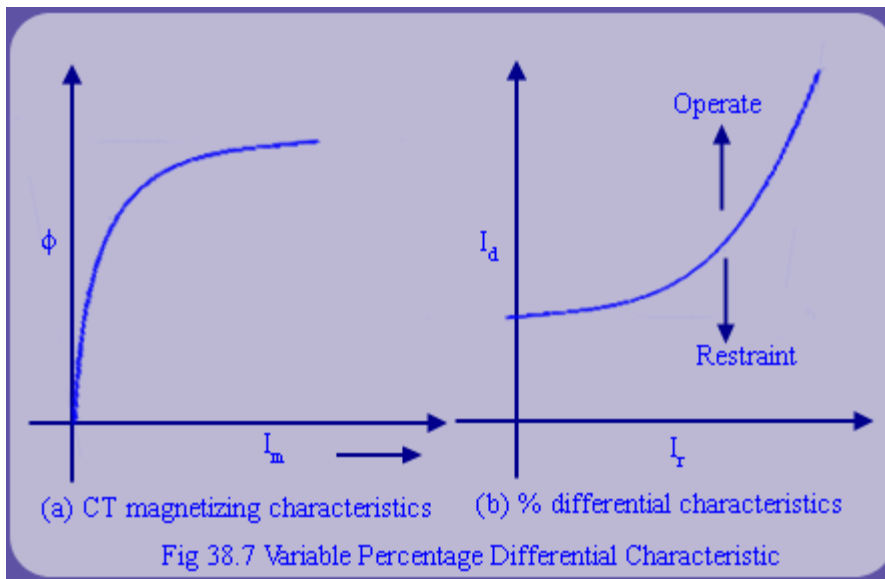

scheme can be devised by instantaneous sample based differential protection scheme. In contrast, a phasor summation scheme will be inherently slower as correct phasor estimates will have to wait until the moving window is totally populated with post fault current samples. One way out of this imbroglio is to use a smaller data window (e.g. 3 sample window).

On the other hand, the comparison scheme based computation of instantaneous samples can be error prone due to noise transient related problem. To obtain reliability, it is necessary that consistent differential current should be obtained. A transient monitor function can be used to check that. A transient counter is initialized to zero. If a fault is detected due to presence of differential current, then counter is incremented. Conversely, if counter is greater than zero, and no fault is detected (small enough differential current magnitude) then counter is decremented. If the counter crosses a preset threshold value, trip decision is implemented. This scheme will not trip on transient.

However, in addition to internal faults, it will also trip on external fault. For this purpose, the differential protection relay also has to have an inbuilt feature to detect CT saturation. One way to detect CT core saturation is based on measuring current change in consecutive samples with the expected sinusoidal signal model. A change much beyond the expected change in sinusoidal model indicates CT core saturation. Many more innovative schemes can be thought out to detect CT saturation which is beyond the scope of this lecture.

Review Questions

1. What is the function of 'NC's shown in fig 38.1.
2. What are the advantages of single breaker double bus arrangement over single bus single breaker arrangement?
3. How does double bus double breaker bus arrangement provides maximum flexibility?
4. What are the advantages of ring bus arrangement?
5. How is CT saturation problem handled in bus protection schemes?
6. Draw the configuration with 6-circuits.

Recap

In this lecture, we have learnt advantages and disadvantages of different bus arrangements like

- Single bus single breaker arrangement.
- Single breaker double bus with bus tie.

- Double bus double breaker.
- Ring bus arrangement.
- One and a half circuit breaker arrangement.
- High impedance bus differential relay.
- B is differential protection using numerical relay.

Congratulations, you have finished Lecture 38. To view the next lecture select it from the left hand side menu of the page