

## EE360 Project

You are to design and simulate an efficient dc power supply without using a single chip converter IC to power electronics in a car. You should compare the performance of your design to the series regulator and to the design using an LTI IC for efficiency and meeting specifications (both should also be simulated for evaluation).

You should upload a written project report and a PowerPoint to present your design and results to the class along with simulation files (Circuit and MatLab feedback) to the appropriate location in BlackBoard.

### A Simple Series Regulator

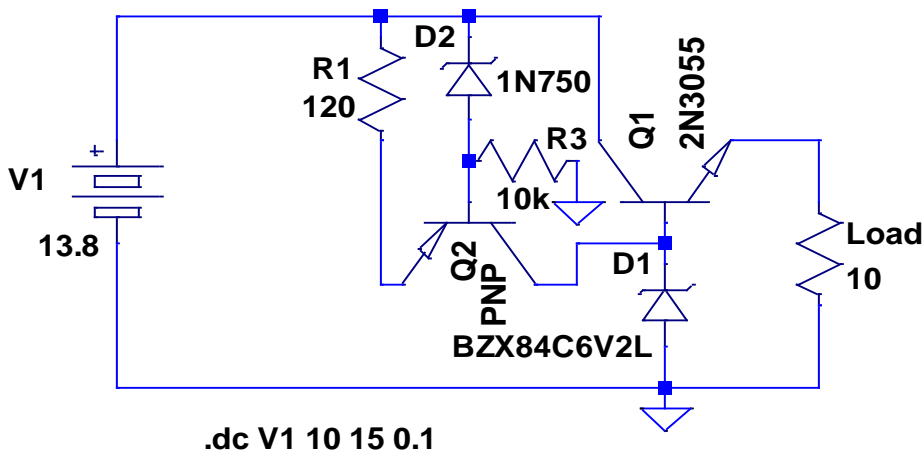

Notes for the series regulator

- D2-Q2-R1-R3 form a constant current supply for D1
- Q1 is a power transistor (see spec sheet) that is used to drop the voltage to about 0.6 volts below the reference voltage set by zener D1. (It is a simple emitter-follower circuit)

### A Buck Converter based on a Linear Technologies chip

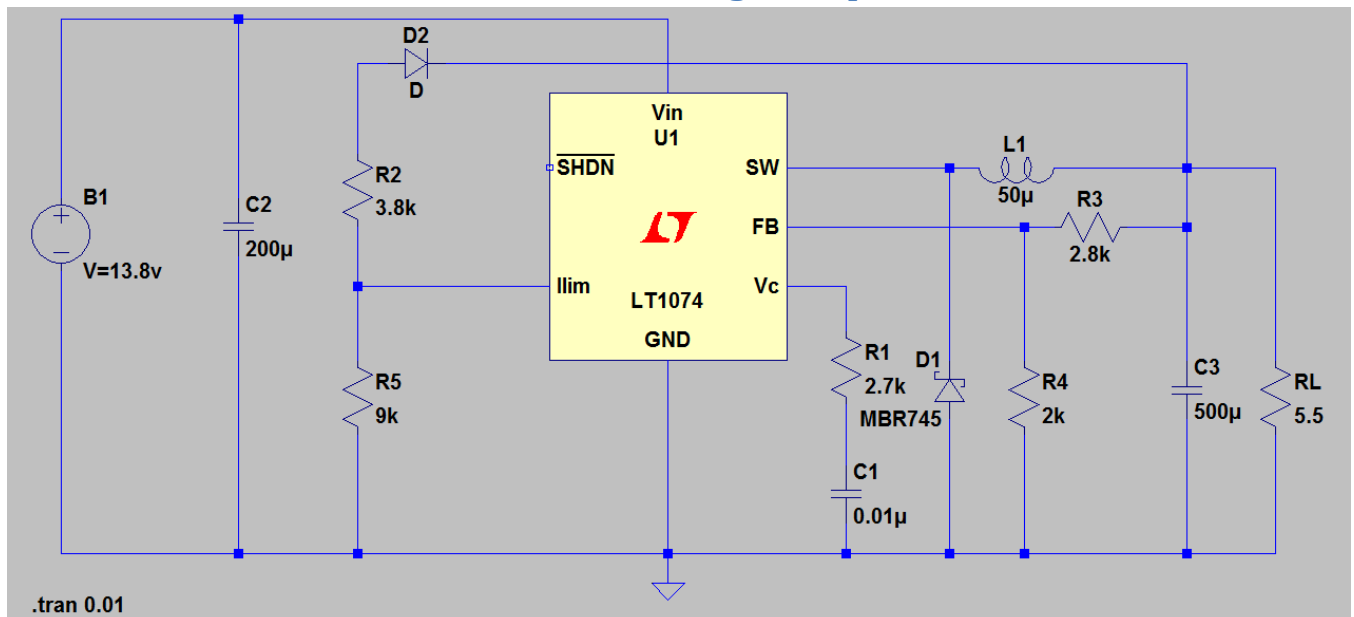

## Specifications:

- The car battery voltage can range from 10 to 15 volts and the system should maintain regulation
- The load current can range from a few milliamps (you can ensure the lower limit with an internal load resistor in parallel with the real load) to 2 amps
- The output voltage is to be  $5.5 \pm 0.5$  volts over varying battery voltage and varying load current.
- Extra credit items
  - Provide short circuit protection for your power supply
  - Using a high frequency isolation transformer in your design
  - Using feedback:
    - Using simple (low gain) feedback control to improve system response to perturbations (Input DC and Load Current)
    - Using an equalizer to allow faster response to perturbations (Input DC and Load Current)
  - Performing a Monte-Carlo Simulation to examine system sensitivity to component tolerances.