

Fuel Cells

Model for
Classroom Instruction
PEMPower® 1-Eco

Instruction Manual
Suggestions for classroom instructions
Experiments

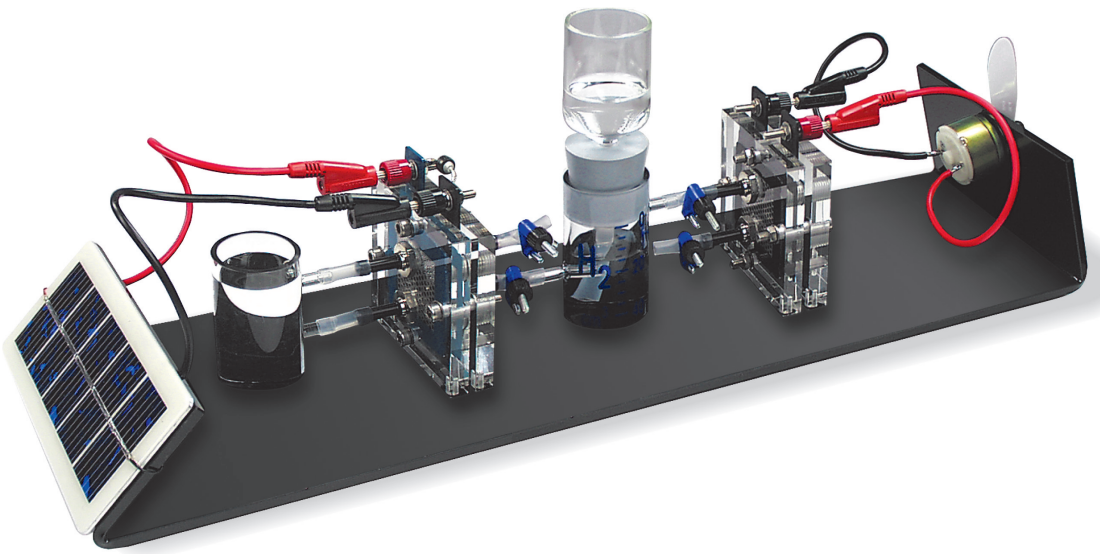

Introduction

Diminishing resources, more severe environmental impacts and the ever-increasing demand for energy force us to reevaluate the structure of our energy supply system. Many companies increasingly invest in hydrogen technology because it offers solutions to some of these concerns. This fascinating technology combines a sound energy supply with minimal impact on our natural resources.

It is important to learn about this technology, especially for students, who will most likely spend a large part of their lives with it.

Give your students the chance to become familiar with hydrogen technology in a step-by-step procedure.

The PEMPower1-Eco, with its straightforward design, will assist you in your efforts.

In this manual you will find the underlying theoretical principles as well as illustrative experiments. Everything was designed specifically for classroom instruction.

From its inception, the PEMPower1-Eco was designed to follow the most environmentally friendly path in all its components, from solar cells that provide the electricity for electrolysis to the fuel cell for independent electricity generation. The system is a model of a complete energy supply system and thus allows you to illustrate both how the individual components of hydrogen technology work and also how these components fit into the larger picture of a hydrogen technology based energy supply system.

All our modules are state of the art and have been designed specifically for classroom instruction. Whether you want merely to show the basic principles of hydrogen technology or to take quantitative measurements of solar cell,

electrolyzer or fuel cell performance, with the PEMPower1-Eco you can do both.

This manual is more than a simple lab guide. In addition to detailed instructions for experiments and results you will also find information on the context and background as well as on the principles of hydrogen technology.

Figures and diagrams throughout the text will assist you and your students in the learning process. Questions and problems are aimed at deepening students' understanding. The problems can be worked on independently or in groups, in class or at home. All solutions are included for quick reference and to provide ideas and suggestions for teaching.

ICON USED IN THIS MANUAL

The icon represents a student or group of students and is placed at the top of the provided worksheets with the students can work on alone or in groups.



Table of contents

| | | |
|----|---------------------------------------|---|
| 1. | Safety Precautions | 4 |
| 2. | Technical Specifications | 6 |
| 3. | Maintenance | 7 |
| 4. | Instruction Manual | 8 |



Suggestions for classroom instructions

| | | |
|------|--|----|
| 5. | Review of today's Energy Industry | |
| 5.1. | Possibilities of generating energy | 10 |
| 5.2. | Electricity producing energy sources..... | 11 |
| 5.3. | Who contributes to the Greenhouse effect..... | 12 |
| 6. | Principles of hydrogen technology | |
| 7. | System components (What they are and how they work) | |
| 7.1. | Solar cell..... | 15 |
| 7.2. | Electrolyzer..... | 16 |
| 7.3. | Gas storage tank | 18 |
| 7.4. | Fuel cell | 19 |
| 8. | Solutions and suggestions for classroom instruction | 20 |

Experiments

| | |
|--|----|
| 9. Generating electricity with the solar cell | |
| 9.1. Photoelectric current and no-load voltage as a function of the distance and angle of incidence between light and solar cell | 26 |
| 9.2. Current-voltage characteristic of the solar cel | 28 |
| 10. Producing hydrogen in the electrolyzer | |
| 10.1. Current-voltage characteristic of the electrolyzer | 30 |
| 10.2. Faraday's first law and elctrolyzer efficiency | 31 |
| 11. Using hydrogen in the fuel cell | |
| 11.1. Current-voltage characteristic of the fuel cell | 34 |
| 11.2. Faraday's first law and fuel cell efficiency | 36 |

Appendix

| | |
|---|-----------|
| 12. Foils | |
| 12.1. To get an idea of the size of an oil field | 41 |
| 12.2. Principles of solar hydrogen technology | 42 |
| 12.3. Solar cell | 43 |
| 12.4. PEM Electrolyzer and PEM Fuel cell | 44 |
| 12.5. Comparison: Traditional energy system with hydrogen energy system | 45 |
| 13. Experiments for students | |
| Generating electricity with the solar cell | |
| 13.1. The photoelectric current and the no-load voltage as a function of the distance and angle of incidence between light and solar cell | 47 |
| 13.2. Current-voltage characteristic of the solar cell | 48 |
| Producing hydrogen in the electrolyzer | |
| 13.3. Current-voltage characteristic of the electrolyzer | 49 |
| 13.4. Faraday's first law and electrolyzer efficiency | 50 |
| Using hydrogen in the fuel cell | |
| 13.5. Current-voltage characteristic of the fuel cell | 52 |
| 13.6. Faraday's first law and fuel cell efficiency | 53 |
| 14. Contact | 54 |

1. Safety Precautions

The PEMPower1-Eco produces hydrogen and oxygen. Warning: these gases can be dangerous when improperly handled. Please take the following safety precautions:



1. **NO SMOKING**



2. **NO OPEN FIRES**

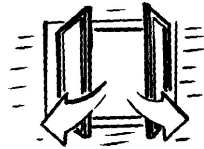

3. **GOOD VENTILATION**

4.

The solar module must not be operated with focused light. Ensure proper distance between light source and solar module.

Using H-TEC lamp "Videolight" (Art.-No.: 1931) the minimum distance is 40 cm.

Using other lamps you must note the minimum distances from the manufacturer.

5.

When you do an experiment involving the electrolyzer make sure the storage tanks always contain enough distilled water.

Do not glue the rubber stopper to the storage tanks. It serves to balance out the pressure.

6.

Inform your students about possible dangers.

Safety Precautions

The hydrogen technology demonstration model PEMPower1-Eco produces and uses oxygen and hydrogen from deionized water. These gases can be potentially dangerous.

- **CAUTION:** Take precautions that no one is endangered by these gases! This is particularly important during operation procedures when these gases are allowed to escape into the environment.
- **Note:** Read your national regulations regarding the handling of hydrogen and oxygen!

Before starting the electrolysis process:

1. Produce adequate circulation and replacement of room air to assure continuous and rapid dilution and removal of any oxygen and hydrogen that may be intentionally or unintentionally released by electrolysis. If continuous circulation and replacement of room air is not assured, do not connect the electrolyzer to any electrical power source.
2. Remove to a distance of at least three meters from the electrolyzer to all ionizing radiation sources, spark producers, Bunsen burners, open flames, incandescent heating elements, and other potential ignition sources.
3. Remove to a distance of at least three meters from the electrolyzer any and all materials that could auto-ignite or degrade in the presence of oxygen-enriched air.
4. This product is intended only for educational demonstrations in which small amounts of oxygen and hydrogen are stored at or near ambient atmospheric pressure at any given time.

Always maintain the water levels between the designated minimum and maximum limits to prevent collection of any greater amounts of oxygen and/or hydrogen.

5. Lightly insert to produce a seal but never hinder the pressure-relief rubber stoppers at the top of each water column from releasing any pressure substantially over the ambient pressure. In other words do not place adhesive tape, weights or any other device on these pressure relief stoppers.

This electrolysis product has been utilized successfully and safely in many thousands of person-hours in educational situations. Please use the product according to the above noted suggestions for safe operation and continue to add to the safe-use record of this educational product.

The system PEMPower1-Eco has been developed exclusively for demonstration and teaching purposes. The functions of PEM electrolyzers and PEM fuel cells (PEM = proton exchange membrane) can be demonstrated and studied both qualitatively and quantitatively with this system.

Every other usage is inadmissible!

When a DC voltage is applied, the electrolyzer divides deionized water (conductivity $< 2\mu\text{S}/\text{cm}$) into oxygen and hydrogen. These gases are then led to the fuel cell where they are combined back to water. This final process generates electricity which can then be used for further applications.

2. Technical specifications

Solar cell:

| | |
|--------------|--------------------|
| Surface: | 90 cm ² |
| Current: | 300 mA |
| Voltage: | 2,5 V |
| Power (MPP): | 0,5 W |

Electrolyzer PEMEL – Pro:

| | |
|---------------------|--------------------|
| Electrode Surface: | 16 cm ² |
| Power: | 2 W |
| Admissible Voltage: | 0 – 1,9 V = |
| Admissible Current: | 0 – 2 A = |

Gas storage tank:

| | |
|---------|--------------------|
| Volume: | 40 cm ³ |
|---------|--------------------|

Fuel cell PEMFC–Kit:

| | |
|---|--------------------|
| Electrode Surface: | 16 cm ² |
| Power (H ₂ / O ₂): | 600 mW |
| Power (H ₂ / air): | 300 mW |
| Voltage Range (approx.): | 0,3 – 0,9 V |

Fan:

| | |
|--------|-------|
| Power: | 20 mW |
|--------|-------|

Complete unit:

| | |
|---------|--------|
| Height: | 175 mm |
| Wide: | 530 mm |
| Depth: | 150 mm |
| Weight: | 1,5 kg |

3. Maintenance

3.1. Electrolyzer

The electrolyzer does not require maintenance. However, please note the following:

- Wrong polarity will destroy the electrolyzer. Connect the cables red to red and black to black.
- Never operate the electrolyzer at a voltage higher than 2.0 V.
- Always use fresh, deionized (distilled) water (conductivity < 2 $\mu\text{S}/\text{cm}$).

3.2. Fuel cell

The fuel cell does not require maintenance. However, please note the following:

- Never apply an electrical power supply directly to the fuel cell! This could immediately destroy the fuel cell.
- If the fuel cell does not work or performs poorly there are several possible reasons:
 - The membrane is dried out.
 - Normally, the membrane automatically is moistened during operation. In addition, it can be moistened with distilled water using a squirt bottle.
 - Particles in the air can contaminate the membrane.
 - The membrane can be rinsed with hydrogen by opening both clamps on the fuel cell for a short period of time.

3.3. After operation

- The distilled water needs to be removed from the hydrogen storage tank and the water expansion cylinder.
- The base should be dried to avoid water markings.

4. Instruction Manual

1. Please read the safety precautions on page 4-5.

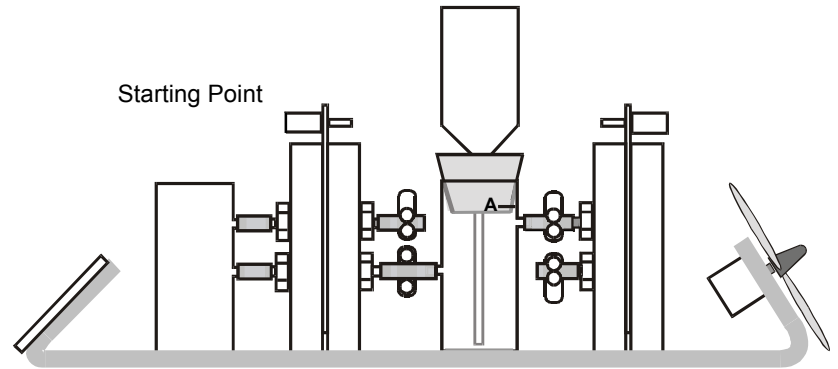

2. Fill the water tank with distilled water. Do not use tap water.

The electrolyzer's top clamp must be closed.

The electrolyzer's bottom clamp must be open.

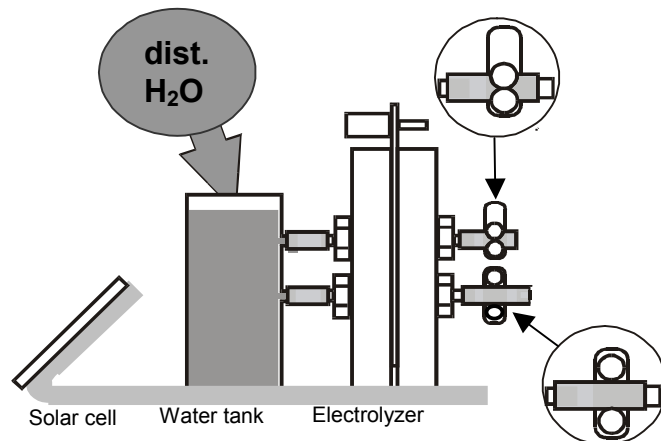

3. Close fuel cell's top clamp.

Take off the expansion cylinder with rubber stopper.

Fill the hydrogen storage tank with distilled water up to the A mark.

Replace the expansion cylinder.

The fuel cell's bottom clamp is pre-set to the closed position; however, it can also be open in this step.

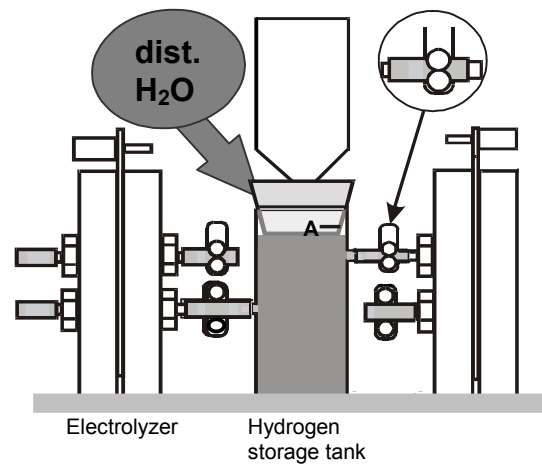

4. Connect solar cell and electrolyzer. Make sure the polarity is correct!

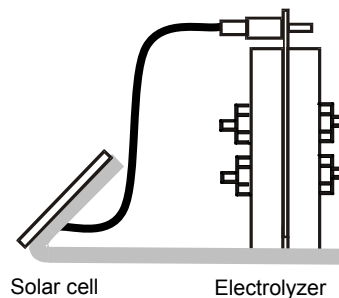

5.
Connect fan and fuel cell.

Both clamps on the fuel cell must be open.

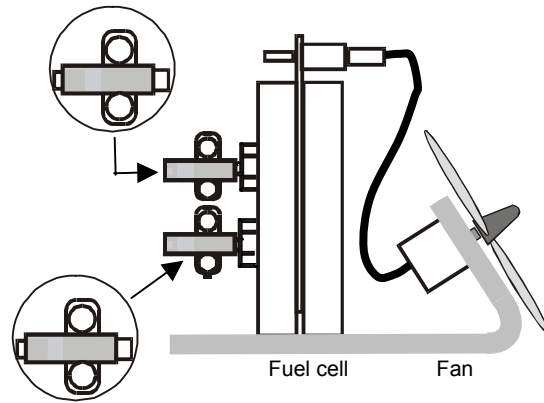

6.
Illuminate the solar cell

Instead of sunlight, a lamp (approx. 500W) can be used for this purpose.
The distance between solar cell and lamp should be about 50 cm.

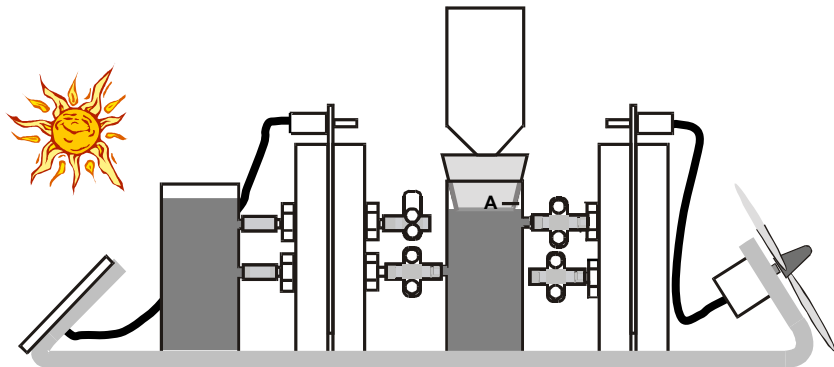

! This distance is only valid for H-TEC lamp "Videolight" (Art.-No.: 1931) !

7.
The fuel cell's bottom clamp can be closed when no more water comes out.

The hydrogen is now being stored.

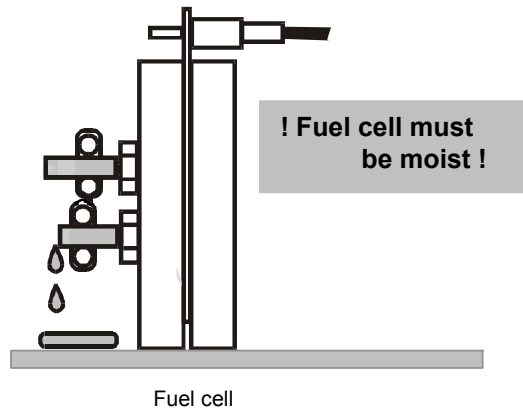



5. Review Of Today's Energy Industry

5.1. Possibilities of generating electricity

There are many different inventions using electricity that we don't want to give up. Every day, people use electricity to produce and manufacture products as well as use these products in every day life. For example the electric light, the TV, the microwave etc. However, the production of electricity has consequences which need to be considered.

Questions and problems

1. Electricity can be generated in many different ways. Name as many as you can think of.
2. What are the advantages and disadvantages of these methods?

| Energy generated by | Advantages | Disadvantages |
|---------------------|------------|---------------|
| | | |

3. In your opinion, what are the characteristics an ideal energy source should have?

5.2. Electricity Producing Energy Sources



Portion of global electricity production provided by various energy sources (1997)

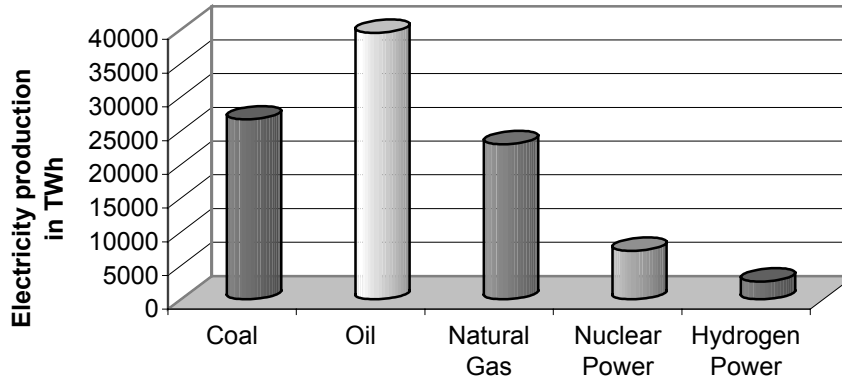

Figure 1

**Global resources of various energy sources (1997)
(by a constant consumption)**

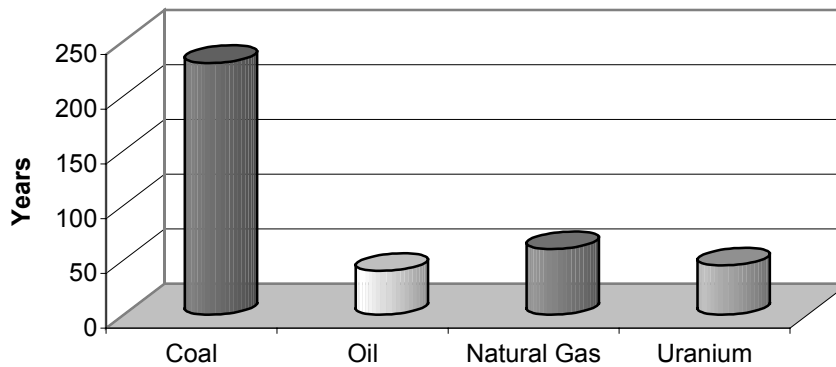

Figure 2
Source: BP Statistical Review of World Energy 1998

Questions and problems

1. Interpret figures 1 and 2 in context.



5.3. Who contributes to the greenhouse effect?

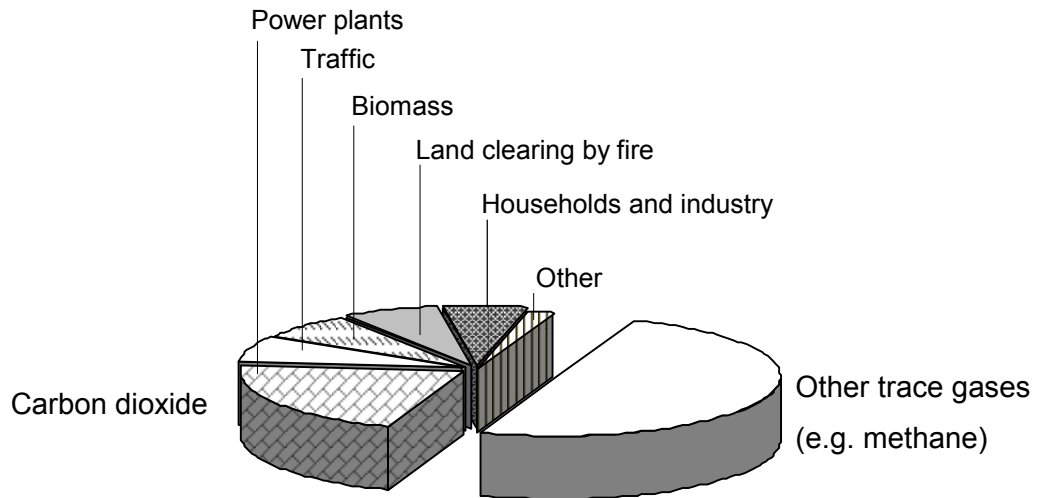

Figure 1

Questions and problems

1. CO₂ contributes greatly to the greenhouse effect. The table below will help you understand where CO₂ is produced and how CO₂ production can be avoided. Fill the table with examples.

| | Produce CO ₂ | Do not produce CO ₂ |
|----------------------|-------------------------|--------------------------------|
| Power plants | | |
| Traffic | | |
| Household appliances | | |

2. How can we reduce CO₂ emissions?



6. Principles Of Hydrogen Technology

All common energy supply systems have disadvantages such as limited resource availability, environmental impacts, low efficiency, or health hazards. This is why research is done to find an energy source that is able to satisfy our demand for energy but at the same time does not have the problems listed above.

Some of the ideas presented here are not new: more than a hundred years ago, in his novel "The Mysterious Island," Jules Verne had one of his characters, the American engineer Cyrus Harding, proclaim: "I believe that, one day, water will be fuel." Was he right?

Can water be fuel?

Yes, he was right, water can be fuel. In nature, this process has had widespread applications for millions of years. Plants produce their nutrients using water and light, in a process called photosynthesis. The light energy is used to split water into oxygen and hydrogen; the hydrogen is then transformed into glucose and thus stored as nutrient/food.

Processes like these consist of three steps: 1. the splitting of water, 2. the storage of hydrogen and 3. the subsequent transformation of chemical energy into other forms of energy. In the case of plants, step 3 is the transformation of one form of chemical energy (hydrogen) into another (glucose) that can be used by the plants. In hydrogen technology, step 3 is a transformation of chemical energy (hydrogen) into electrical energy.

In 1820, Michael Faraday (1791-1867) formulated the principle of electrolysis: electric currents can be used to separate an electrically conducting fluid into its components, e.g. water is separated into hydrogen and oxygen or a copper chlorine solution is separated into copper and chlorine.

About 20 years later the French scientist Alexandre Edmond Becquerel (1820-1891) discovered that some materials produce a current (electricity) when light shines on them. He had discovered the principle of solar cells.

Today, scientists and engineers apply both of these principles to make hydrogen part of our future's electricity supply system.

The electricity generated in a solar cell is used to separate water into hydrogen and oxygen. Later, these gases are used to produce electricity. Isn't that redundant?

Yes, but only at first sight. What is the disadvantage that both solar energy and wind energy have in common?

The problem with these energies is that supply and demand rarely coincide, neither in time nor in space. For example, electricity is needed both during the day and at night but solar energy can be produced only during the day. Moreover, many of the areas that receive a lot of sunlight are located in Africa while the largest demand for electricity is in Europe and North America. Since it is very expensive to transport electricity, we need other, cheaper ways to store and transport the energy.

Hydrogen is one such energy reservoir. It can very easily be produced by splitting water by means of solar energy. It can then be transported and stored in a way similar to natural gas. (See also page 18)

Later, hydrogen is used to produce electricity, in a process that is opposite to what happens in electrolysis. Instead of splitting water into its constituents, water is now produced by recombining the transported and stored hydrogen with oxygen. Instead of using electric energy, it is now produced. All of this can be done in a device called a fuel cell.

Although the idea of a fuel cell has been around since its discovery in 1839 by Sir William Robert Grove (1811-1896), until recently there were only a few applications, predominantly in space exploration. However, due to environmental pollution and diminishing resources, fuel cells have gained in importance in recent years.

Other kinds of high tech fuel cells use the chemical energy stored in methanol or other hydrocarbons to produce electricity. These fuel cells use the same traditional energy sources as today's engines while causing far less pollution.

Fuel cell development has now advanced to a level that allows to drive a regular car for about 400 km with one tank of hydrogen, and all of this free of pollution.

The following diagram shows the various concepts for powering a car:

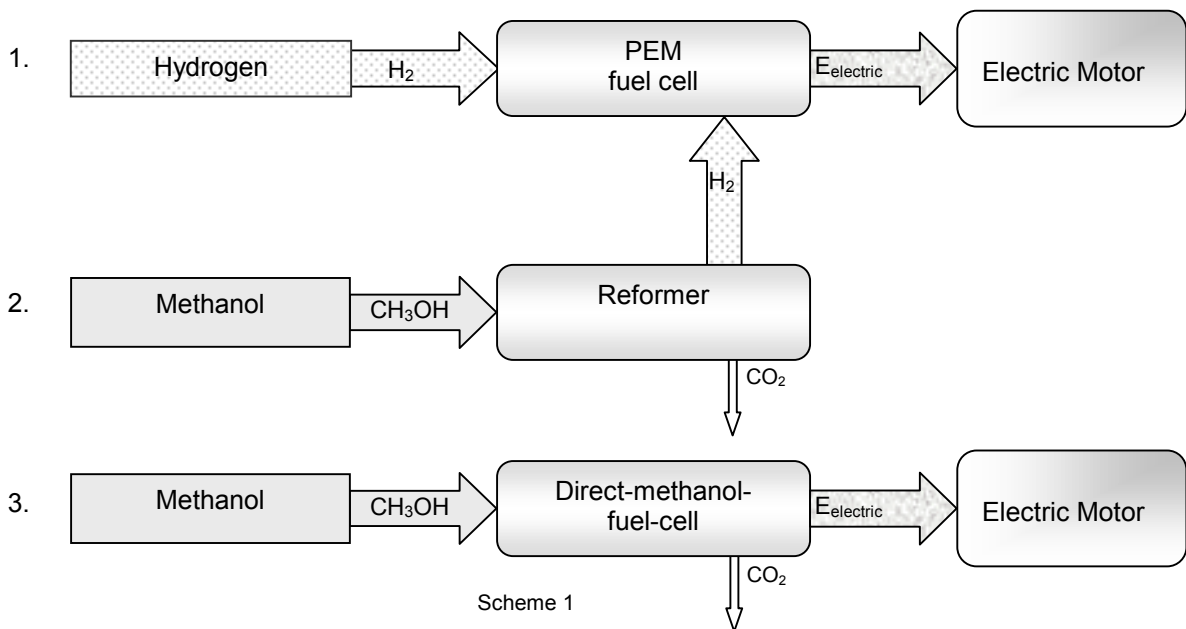

Questions and problems

1. Describe the steps that are necessary to produce electricity from hydrogen.
2. Look up information about the scientists who have made significant contributions to this field.
3. Find further applications for fuel cells.

7. System components (What they are and how they work)



7.1. Solar cell

Solar cells allow us to transform light energy into electric energy.

The solar module and the fan in Figure 1 are directly connected. To start the fan you only need to shine a light on the solar module. Cover the solar cell and the fan will stop running. Opposite polarity will cause the fan to rotate in the opposite direction. Solar cells generate a DC current.

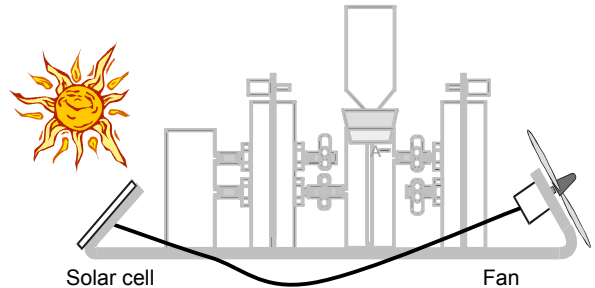

Figure 1

Solar cell technology is based on materials known as semiconductors which consist of selected crystals like, for example, silicon or germanium.

At room temperature, the attractive forces that hold the electrons in their place in the crystal lattice are small. Light energy or heat energy can boost the electrons to leave their place and become free charge carriers.

The conductivity of semiconductors can be increased by adding small amounts of certain elements (e.g. phosphorus or boron). This procedure is called doping. Doping leads to an increase in the number of free charge carriers and the treated semiconductor is now called an N-type or P-type semiconductor, depending on the type of element used. A solar cell is basically a combination of N- and P-type semiconductors.

When light shines on the P-N-type boundary layer, electrons are set free. The electric field between the two layers results in a separation of positive and negative charge carriers. This turns the solar cell into a source of electric power that has a voltage of approximately 0.5 V. If a larger voltage is desired, several solar cells are connected in series.

Solar cells produce electricity in an environmentally friendly way but this is not their only advantage.

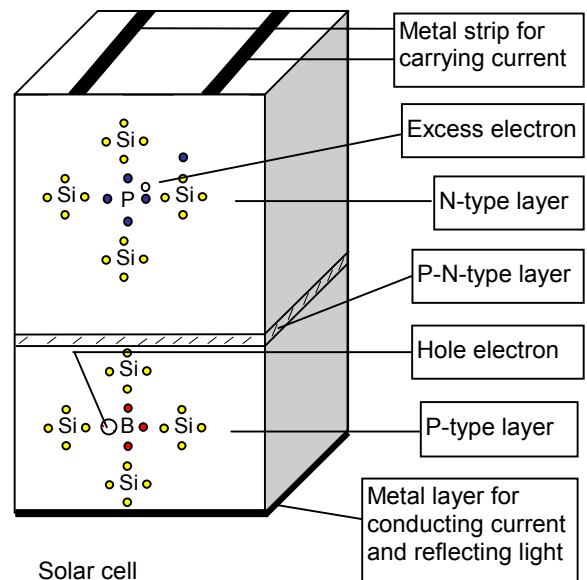

Solar cell
(not to scale)

Questions and problems

1. Name further advantages of solar cell technology.
2. Think about what other effects could influence the performance of the solar cell. Try to prove your thoughts by creating an experiment.



7.2. Electrolyzer

Electrolysis: from the Greek word *lyein*=to dissolve. In 1795, in Oxford, England, Dr. Asch discovered the ability of electric currents to dissolve the chemical bonds in water (or similar substances).

The following experiment shows how water is separated in an electrolyzer.

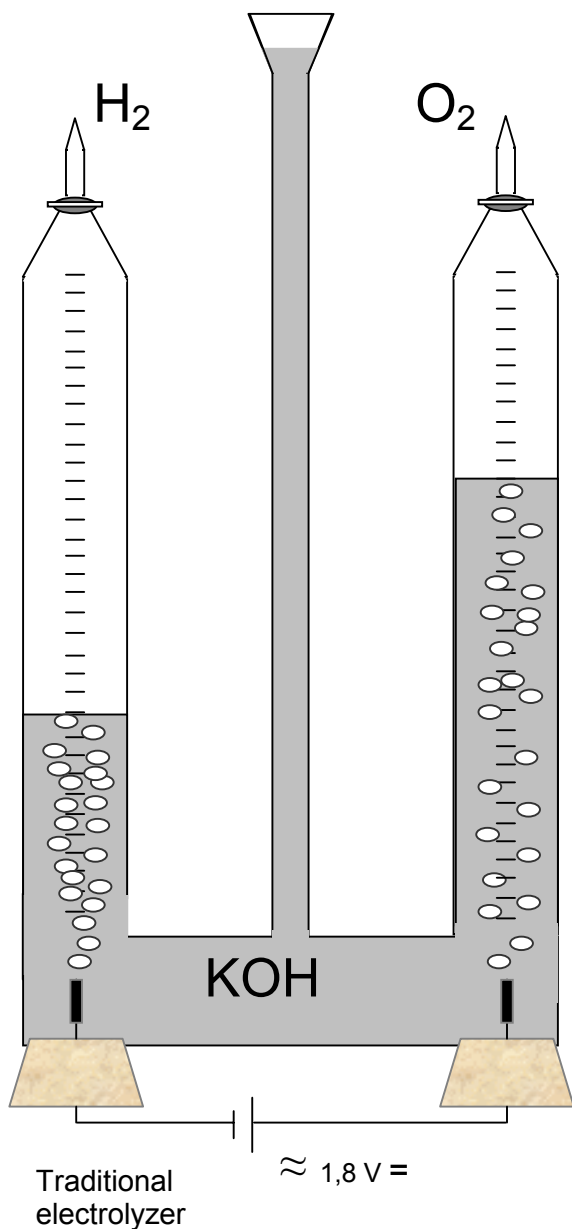

The bubbles rising in the two inverted test tubes indicate gas production. A water molecule is composed of two hydrogen atoms and one oxygen atom. This can also be seen from the volume ratio (2 to 1) of the gas produced in the two tubes.¹⁾ One might conclude that hydrogen is produced at the cathode (the electrode connected to the negative pole) and oxygen at the anode (the electrode connected to the positive pole).

One can check both with the flame test.

1. Test for oxygen: a glowing wood splint is held into the test-tube from the top. The oxygen will cause it to flame up brightly.
2. Test for hydrogen: a glowing wood splint is held into the test-tube from below. The hydrogen will burn with a bang.

Warning: To avoid an explosion too strong keep the glass tube closed until you begin with the flame test.

¹⁾ The volume ratio will be exactly 2 to 1 only for platinum electrodes. If nickel or copper electrodes are used the oxygen produced will react with the electrode material thereby changing the volume ratio.

More traditional electrolyzers use fluids that facilitate the splitting of water, however, these are being replaced more and more by PEM technology.

PEM stands for Proton Exchange Membrane. The central part of the PEM technology is a thin, proton-conducting polymer membrane that is covered with a layer of catalyst material on both sides. These two layers form the cell's cathode and anode.

With this arrangement the chemical reactions are:

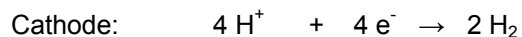
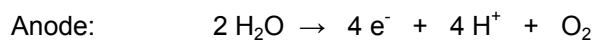

The H^+ ions (i.e. the protons) move through the proton-permeable membrane to the cathode and combine with electrons from the electric circuit to form hydrogen.

Basic principle of a PEM electrolyzer

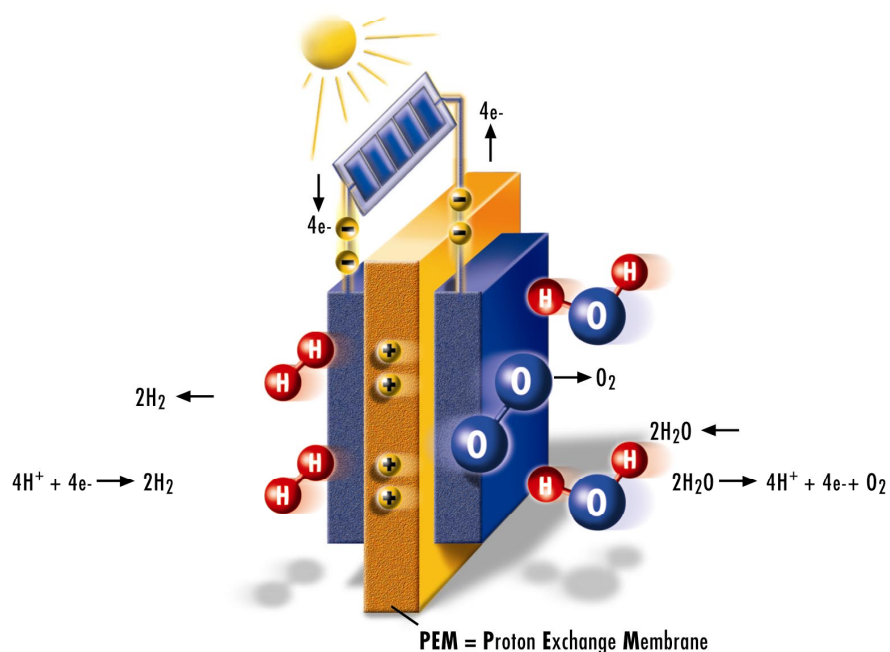

Questions and problems

1. Describe the basic principles of an electrolyzer.
2. How are these principles at work in a PEM electrolyzer?



7.3. Gas storage tank

The hydrogen-oxygen gas reaction in chapter 7.2. suggests concerns regarding the safety of hydrogen technology.

As a gas, hydrogen is able to escape from most containers extremely easily. If it is then mixed with oxygen the resulting gas mixture is highly explosive. However, experience has shown that the risks are similar to those in handling petrol and natural gas.

Hydrogen is most commonly stored and transported either as a gas or as a liquid. The same amount of hydrogen occupies almost 900 times the volume when stored as a gas as compared to when stored as a liquid. Therefore, large amounts of hydrogen can most easily be transported through pipelines (similar to natural gas). In order to transport smaller quantities the hydrogen is usually stored under high pressure (approximately 200 bar¹⁾) or even cooled down to its boiling point. In the latter case the hydrogen is now in its liquid state and has to be kept at a temperature of -253°C.

Other possibilities include the transformation of hydrogen into methane or its storage in chemical compounds such as metal hydrides or nanographite. The latter option is still in its developing phase. Storing hydrogen in metal hydrides has a disadvantage similar to lead-based rechargeable batteries: they have a lot of weight for the amount of energy stored.

Questions and problems

1. The two largest catastrophes in the twentieth century that involved hydrogen were the conflagration of the zeppelin *Hindenburg* and the explosion of the space shuttle *Challenger*. Find information about these two events.

¹⁾ 1 bar = 100 kPa (or approximately one atmospheric pressure)



7.4. Fuel cell

A fuel cell is an electrochemical electricity source. Electricity is produced in a process of reversed electrolysis.

Materials like platinum are used to a) separate the electrons from the hydrogen (leaving hydrogen ions or protons) and b) split and ionize the oxygen. This causes an electric voltage between the electrodes. When connecting the electrodes in an electric circuit two things happen:

1) the electrons move through the electric connection to the oxygen at the cathode thereby ionizing the oxygen and

2) the hydrogen ions (protons) move through the proton permeable membrane to the cathode. Protons and oxygen ions react to form the 'waste product' water.

A single cell can generate a voltage of about 1V. By stacking cells and connecting them in series it is possible to get voltages up to 200V. Fuel cells have an electric efficiency of about 50% and produce absolutely no pollutants when operated with hydrogen.

Basic principle of a PEM fuel cell

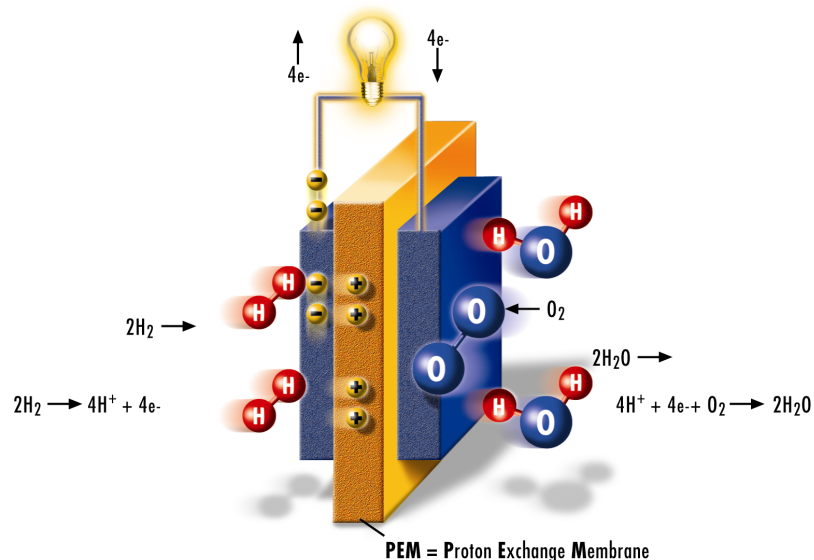

Questions and problems

1. Complete the following reactions and sign the oxidation and the reduction:

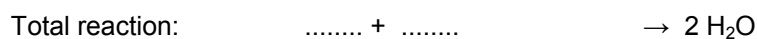
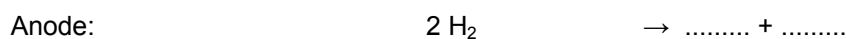

8. Solutions and suggestions for classroom instruction

Solutions to chapter 5.1.

1. Energy production by:

| | |
|------------------------|---|
| Coal, oil, natural gas | Solar energy |
| Nuclear power | Water power, wind energy, biomass (indirect forms of solar energy) |

2.

| Energy source | Advantages | Disadvantages |
|----------------------|---|---|
| Coal | Can be mined easily | Environmental impact, low efficiency |
| Water power | Environmentally friendly, inexhaustible supply | Not available everywhere |
| Nuclear power | Good efficiency, low CO ₂ emission | Dangerous, requires sophisticated and expensive technology |
| Wind energy | Environmentally friendly, inexhaustible supply | Low energy yield, cannot be used everywhere, requires large area |
| Natural gas | Reasonably good efficiency | No Zero Emissions technology |
| Oil | Advanced processing technology | Environmental impact, limited resources |
| Solar energy | Environmentally friendly, inexhaustible supply | Not yet economically feasible, energy supply does not cover demand, requires large area |

3. The ideal energy source should have the following characteristics:

- Environmentally friendly
- Inexhaustible supplies
- High efficiency, in large and small units
- Continuous supply of energy (day and night)
- High reliability
- Low noise level

Solution to chapter 5.2.

1. About 90% of our electricity demand is covered by oil, coal, and natural gas. Besides the pollution, we need to consider the limited nature of these resources.

The exact size of resources is not known. However, the figure shows present estimates that take into account consumption of not only electricity but also other forms of energy. These include, for example, cars, households, and the chemical industry.

At the moment there is a diametric relationship between resource availability and usage.

One alternative is solar energy. One percent of the energy radiated by the sun every second ($7 \times 10^{17} \text{ J}$) would cover the global energy demand which is 10^{13} J every second.

Presently, concepts for using the sun's energy involve both direct and indirect methods.

The direct usage of solar energy includes solar cells and solar heating systems.

Water power is an example of the indirect usage of solar energy. The mountain lakes that feed the turbines in a power plant were created by evaporation and cloud generation, i.e. processes powered by solar energy.

Solutions to chapter 5.3.

1. Examples

| | Produce CO ₂ | Do not produce CO ₂ |
|-----------------------------|---|---|
| Power plants | Power plants using fossil fuels like coal, oil, natural gas | Nuclear power plants Solar power plants Water power plants Wind power plants Fuel cell power plants |
| Traffic | Gas and diesel powered cars and trucks | Electric cars Solar cars Cars powered by fuel cells ¹⁾ Bicycles |
| Household appliances | Gas stove, oil heating | Vacuum cleaner Electric stove ²⁾ |

¹⁾ Methanol powered fuel cells produce small amounts of CO₂.

²⁾ For electric appliances it is important to know how the electricity was produced.

2. CO₂ emissions have global effects and, therefore, must be reduced on a global scale. To achieve this, the industrialized nations should:

- Increasingly invest in technology that has no CO₂ emissions
- Make this technology available to developing countries
- Lower their electricity and energy consumption.

Electricity and energy consumption can be reduced, for instance, by:

- Cars with better gas mileage
- Increasing the efficiency of electric appliances
- Reducing the fuel demand for heating (better insulation, alternative technologies)

Solutions to chapter 6.

1. Hydrogen can be produced easily by electrolysis of water. This process requires a direct electrical current. However, to be environmentally friendly, renewable sources, such as solar energy should be used to create hydrogen by electrolysis. With the hydrogen created from electrolysis and stored, electrical power can be created from a fuel cell using stored hydrogen when needed.

2. Michael Faraday (1791 – 1867)

English physicist and chemist, known for his research on electrolysis and electromagnetic induction.

He did his first research in chemistry (pressure liquefaction of chlorine, discovery of benzene in 1824).

In 1831, he discovered electromagnetic induction and several other electromagnetic phenomena. He investigated electrolysis and discovered two fundamental laws of electrochemistry.

Alexandre Edmont Becquerel (1820 – 1891)

French physicist (brother of Henri Becquerel, the discoverer of radioactivity), investigated the effects of light on electrochemical phenomena. More widely known for his research on phosphorescence and fluorescence.

Sir William Grove (1811 – 1896)

English physicist, astronomer and lawyer. In 1839, he invented the battery that was named after him - the first fuel cell.

3. Because of cost, fuel cell technology was initially used only in space exploration. In recent years, however, development of this technology has advanced substantially. At present, there are demonstration projects in which busses and cars are powered by fuel cells. Fuel cell technology can be used for decentralized electricity supply for communities, any mode of transportation and even notebooks.

Solutions to chapter 7.1.

1. Solar cells do not require additional fuel to be transported. They do not have moving parts, which makes them extremely easy to maintain and highly reliable. Compared to mechanical systems (which have moving parts) solar cells are very lightweight and durable.

2. A solar cell reaches its maximum performance when provided with clear, natural light. Diffuse or artificial light result in reduced performance. The distance between solar cell and light source, as well as cell area and material also affect the performance. (See also page 26 ff)

Solutions to chapter 7.2.

1. The electrolyzer contains two electrodes made of nickel or platinum. When the two electrodes are placed into an electrolytic liquid and a direct current is applied to the electrodes, hydrogen and oxygen are produced.

2. The PEM electrolyzer is a membrane electrode assembly consisting of a proton permeable polymer membrane with a layer of catalyst material on each side. These two layers act as an anode and cathode of the electrochemical cell.

Gaseous oxygen, electrons and H^+ -ions are produced at the anode when a voltage is applied to the cell. The H^+ -ions cross the proton permeable membrane and reach the cathode where they react with electrons from the external current to form gaseous hydrogen.

Solution to chapter 7.3.

1. When the *Hindenburg* went up in flames it was the first accident in German zeppelin aviation that involved casualties. It also marked the end of the zeppelin era. The *Hindenburg*, the biggest German zeppelin was built with a capacity of 70 passengers and 13 tons of cargo. In its interior it had 200,000 m³ of hydrogen. In the 1930's, helium (which is not flammable like hydrogen) was available only in the United States but it wasn't made available to Germany because of the concern of potential war in Europe. As a result the zeppelin was operated with hydrogen, under increased safety precautions.

Prior to the accident, the *Hindenburg* crossed the Atlantic Ocean 34 times without incidents, reaching destinations in North and South America.

After the fire on May 6, 1937, in Lakehurst, New Jersey, there were widespread suspicions of sabotage but there was no investigation. Thirty-five people died during the fire, most of them because they jumped out of the zeppelin before it landed.

Another tragic accident involving hydrogen happened on January 28, 1986, when the space shuttle *Challenger* exploded a few seconds after takeoff from Kennedy Space Center in Florida, killing all seven crewmembers.

The explosion was caused by a faulty leaking gasket. Hot gases escaped from the acceleration system to the outside and destroyed the accelerator's holding device. The accelerator then cut through the outside tank igniting and exploding the liquid oxygen and hydrogen inside.

Solution to chapter 7.4.

1. The complete reactions are:

Anode: $2 H_2 \rightarrow 4 H^+ + 4 e^-$ (oxidation)

Cathode: $O_2 + 4 H^+ + 4 e^- \rightarrow 2 H_2O$ (reduction)

Total reaction: $2 H_2 + O_2 \rightarrow 2 H_2O$

Further information on the fuel cell:

In contrast to galvanic cells, fuel cells cannot discharge. They operate as long as they are provided with fuel and oxidizing agents from the outside.

Besides hydrogen fuel cells which are the most well known type of fuel cell, there are other types of fuel cells that operate on methanol or natural gas.

A fuel cell directly transforms chemical energy into electric energy. This is different from more conventional techniques which typically convert chemical energy into heat energy (combustion), heat energy into mechanical energy (revolutions inside generator) and, finally, mechanical energy into electric energy. Fuel cells thus are very efficient; they also have low emissions, produce very little noise and are very reliable during continuous operation.

Some other examples for non-conventional energy sources that are in consideration are:

- Non-conventional oil:
 - Oil stored in oil hales or tar-sand instead of regular oil deposits
 - Extraction methods are complicated and expensive (e.g. open pit mining); extraction is limited by environmental factors.
- Methane hydrate:
 - Natural gas and water mixture in solid form.
 - Complicated extraction, during extraction climate impacting methane might be released.
- Nuclear power:
 - If we wanted to replace half of our oil consumption with nuclear power by the year 2050 we would have to build one nuclear power plant per week, starting now.
- Nuclear fusion:
 - Won't be economically feasible for at least 50 years.

One suggestion for a final question on this subject would be the following:

Try to imagine scenarios of what our energy system might look like in 50 years. Take into account both how energy will be available and used. What changes have to be made to realize these ideas?

Discuss the advantages and the disadvantages of your idea.

Here is an example of a possible scenario:

The energy system of the future will be based on hydrogen. This will save our natural resources, and anthropogenic carbon dioxide and other pollutants will no longer harm the environment.

Solar cells in deserts or unpopulated areas, water power plants in Norway and Canada, and wind wheels in coastal regions provide the electricity required for electrolysis.

The hydrogen produced can be transformed into liquid methanol or transported as a gas through pipelines or as a liquid on tankers.

Fuel cells can use the hydrogen to produce electricity for all kinds of purposes, to supply an entire city, a factory, or a detached family house, or to power mobile devices (such as notebooks). All vehicles including cars, busses, trucks, ships, and even planes will move about quietly and almost free of emissions because they are all powered by electric motors and methanol or hydrogen fuel cells.

People today are more conservative with their engine use. In near future, there will be less electricity needed in every day life, lessening the impact on the environment.

9. Generating electricity with the solar cell

9.1. Photoelectric current and no-load voltage as a function of the distance and angle of incidence between light source and solar cell

We are interested in four cases:

- | | |
|---|---|
| A. The dependence of the photoelectric current on distance. | C. The dependence of the photoelectric current on the angle of incidence. |
| B. The dependence of the no-load voltage on distance. | D. The dependence of the no-load voltage on the angle of incidence. |

Experimental setup and procedures: (Case A)

1.

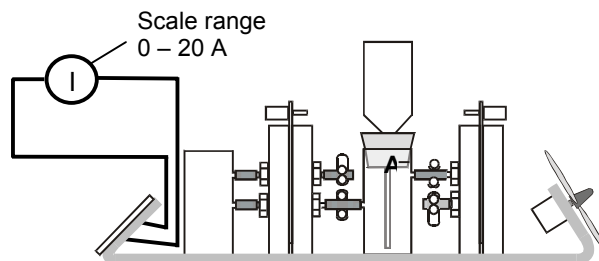

2.

Illuminate the solar cell, measure the distance light source - solar cell & measure the current.

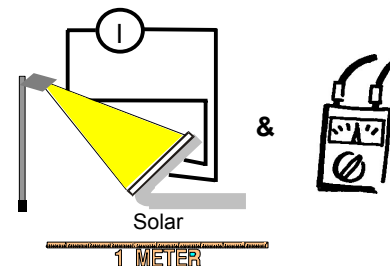

3.

Change the distance light source - solar cell & repeat the last two steps of No. 2

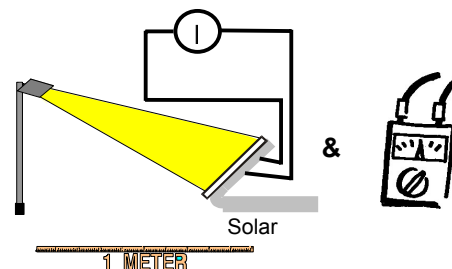

4.

Repeat step 3 several times.

5.

The experimental procedures described in steps 1-4 above were for case A, but can be easily adapted to case B, C and D. The scale range should be set to 0-20 A for current measurements, and to 0-2 V for no-load voltage measurements. We recommend a minimum distance of 40 cm for cases C and D.

! This distance is only valid for H-TEC lamp "Videolight" (Art.-No.: 1931) !

6.

Example results:

| | | | | | | | |
|----------------|------|------|------|------|------|------|------|
| Distance in cm | 30 | 50 | 70 | 90 | 110 | 130 | 150 |
| I in mA | 120 | 90 | 50 | 30 | 20 | 10 | 10 |
| U in V | 2,81 | 2,74 | 2,64 | 2,56 | 2,48 | 2,42 | 2,36 |

Table 1

| | | | | | | | | | | |
|------------|------|------|------|------|------|------|------|------|------|------|
| Angle in ° | 0 | 10 | 20 | 30 | 40 | 50 | 60 | 70 | 80 | 90 |
| I in mA | 94 | 90 | 89 | 84 | 79 | 70 | 57 | 45 | 33 | 22 |
| U in V | 2,73 | 2,72 | 2,71 | 2,68 | 2,67 | 2,64 | 2,62 | 2,55 | 2,52 | 2,45 |

Table 2

Table 1 contains some example data for cases A and B and Table 2 results for cases C and D. The data in Table 1 are plotted in Figure 1. Ideally, the photoelectric current goes down as square of distance while the no-load voltage decreases linearly as function of distance.

A. The dependence of the photoelectric current on distance

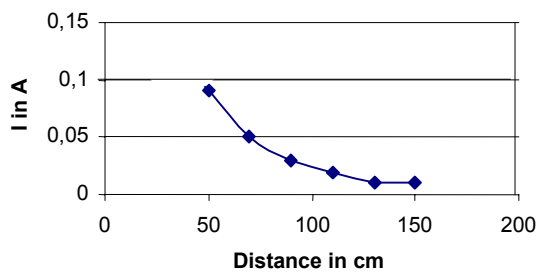

B. The dependence of the no-load voltage on distance

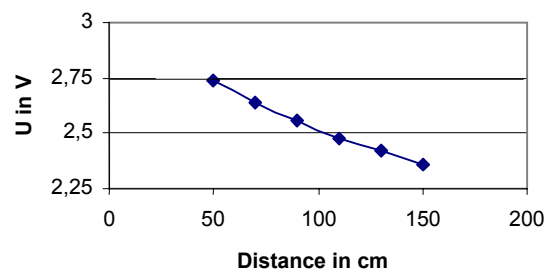
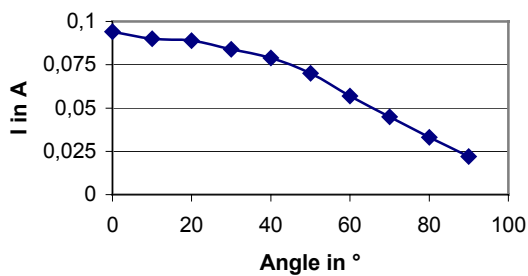

Figure 1

Figure 2 shows the results for cases C and D (see data in Table 2). Both photoelectric current and no-load voltage are directly proportional to the cosine of the angle of incidence.

C. The dependence of the photoelectric current on the angle of incidence



D. The dependence of the no-load voltage on the angle of incidence

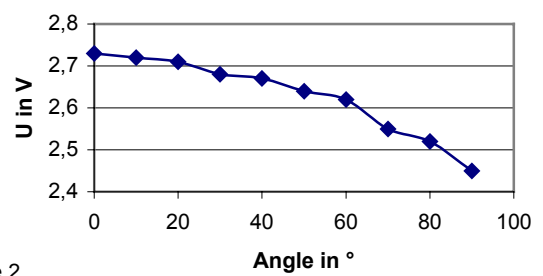

Figure 2

9.2. The current-voltage characteristic of the solar cell

The current-voltage characteristic of the solar cell tells us about the solar cell's performance. It allows the determination of the **maximum power point** (or **MPP**).

Experimental setup and procedures:

1.

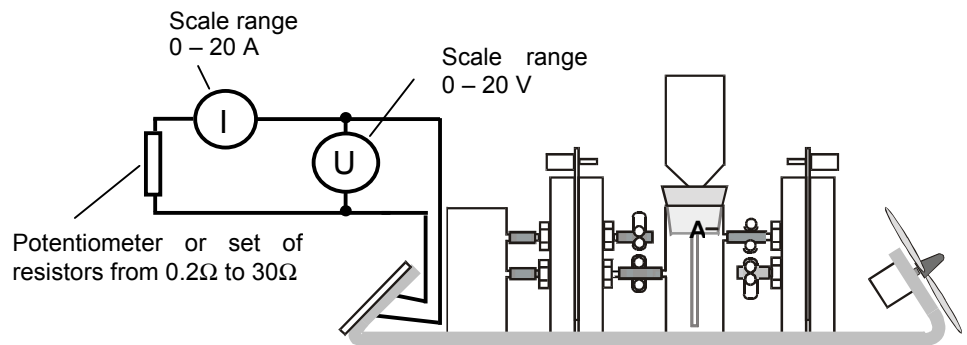

2.

Illuminate the solar cell evenly
&
wait for about 5 minutes to avoid errors due to temperature variation.

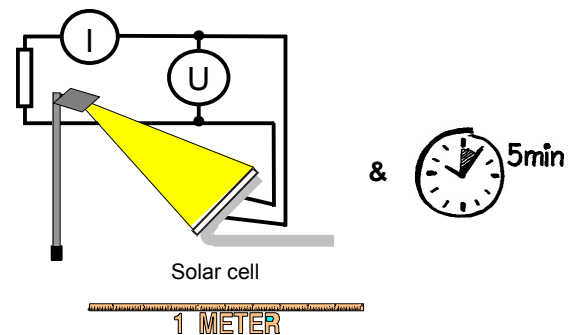

3.

When measuring the current-voltage characteristic start with the no-load voltage and vary the resistance down from large to small.

4.

Example results:

| | | | | | | | | | | |
|---------------|----------|------|------|------|------|------|------|------|------|-----|
| R in Ω | ∞ | 22 | 5,6 | 2,7 | 1,8 | 1 | 0,68 | 0,33 | 0,22 | 0 |
| I in A | 0 | 0,09 | 0,1 | 0,1 | 0,1 | 0,1 | 0,1 | 0,1 | 0,1 | 0,1 |
| U in V | 2,77 | 2,15 | 0,59 | 0,28 | 0,19 | 0,11 | 0,07 | 0,04 | 0,03 | 0 |

Table 3

Current-voltage characteristic of the solar cell

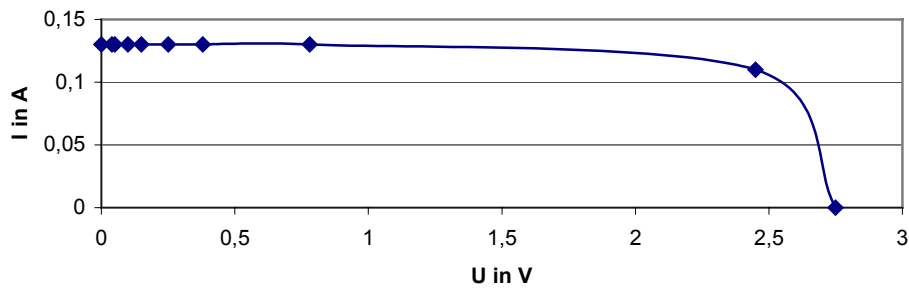

The maximum power point is the point in which the product of voltage and current is the greatest. It can be determined in two different ways:

1. from a P-U diagram (MPP~0.27W)

Power characteristic of a solar cell

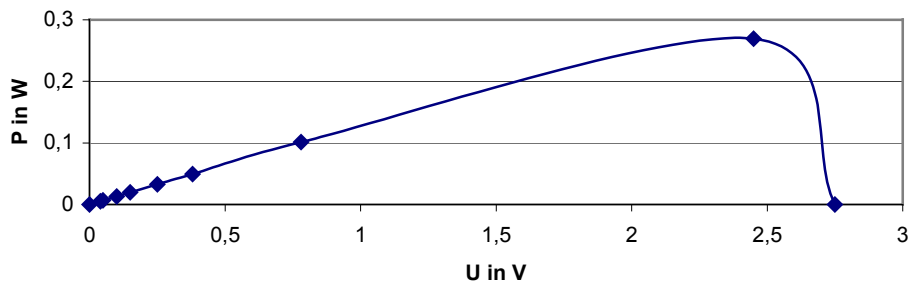

2. from the area of the largest possible rectangle in the I-U characteristic.

The power of the load should always be close to the MPP.

10. Producing hydrogen in the electrolyzer

In this section we suggest two useful experiments that help describe an electrolyzer's performance. In the first experiment we measure the electrolyzer's current-voltage characteristic and in the second its efficiency.

10.1. Current-voltage characteristic of the electrolyzer

Experimental setup and procedures:

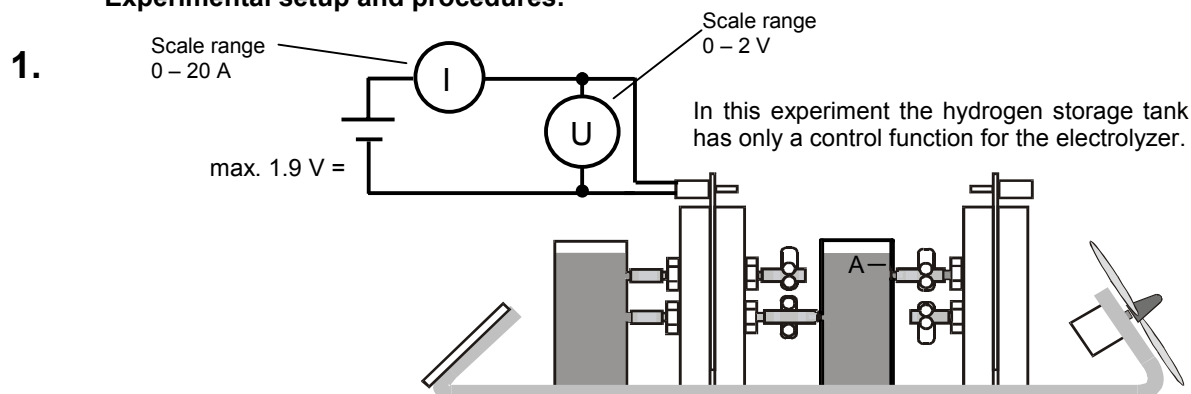

2. Allow the electrolyzer to operate for about one minute at a voltage of 1.8 V.

3. Short circuit the electrolyzer for about one minute, and then reconnect again.

4. Adjust voltage upward from 0 to 1.9 V.

5. Example results:

| | | | | | | | | | | | | |
|--------|---|------|------|------|------|------|------|------|------|------|------|-----|
| U in V | 1 | 1,4 | 1,45 | 1,5 | 1,55 | 1,6 | 1,65 | 1,7 | 1,75 | 1,8 | 1,85 | 1,9 |
| I in A | 0 | 0,03 | 0,05 | 0,1 | 0,2 | 0,3 | 0,4 | 0,55 | 0,66 | 0,8 | 0,94 | 1,1 |
| P in W | 0 | 0,04 | 0,07 | 0,15 | 0,3 | 0,48 | 0,66 | 0,94 | 1,15 | 1,44 | 1,74 | 2,1 |

Linearly extend the steep part of the curve. Its intersection with the x-axis gives the decomposition voltage U_D . For $U < U_D$ there is no electrolysis.

Current-voltage characteristic of the electrolyzer

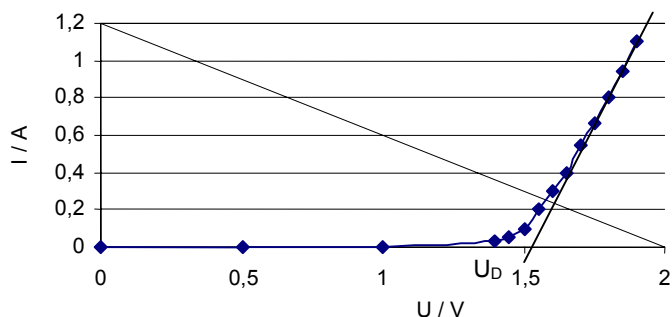

10.2. Faraday's first law and electrolyzer efficiency

Faraday's first law describes the relationship between the current applied to the electrolyzer and the resulting gas production. The electrolyzer efficiency is given by the ratio of actual gas production and theoretical gas production.

FARADAY'S First Law

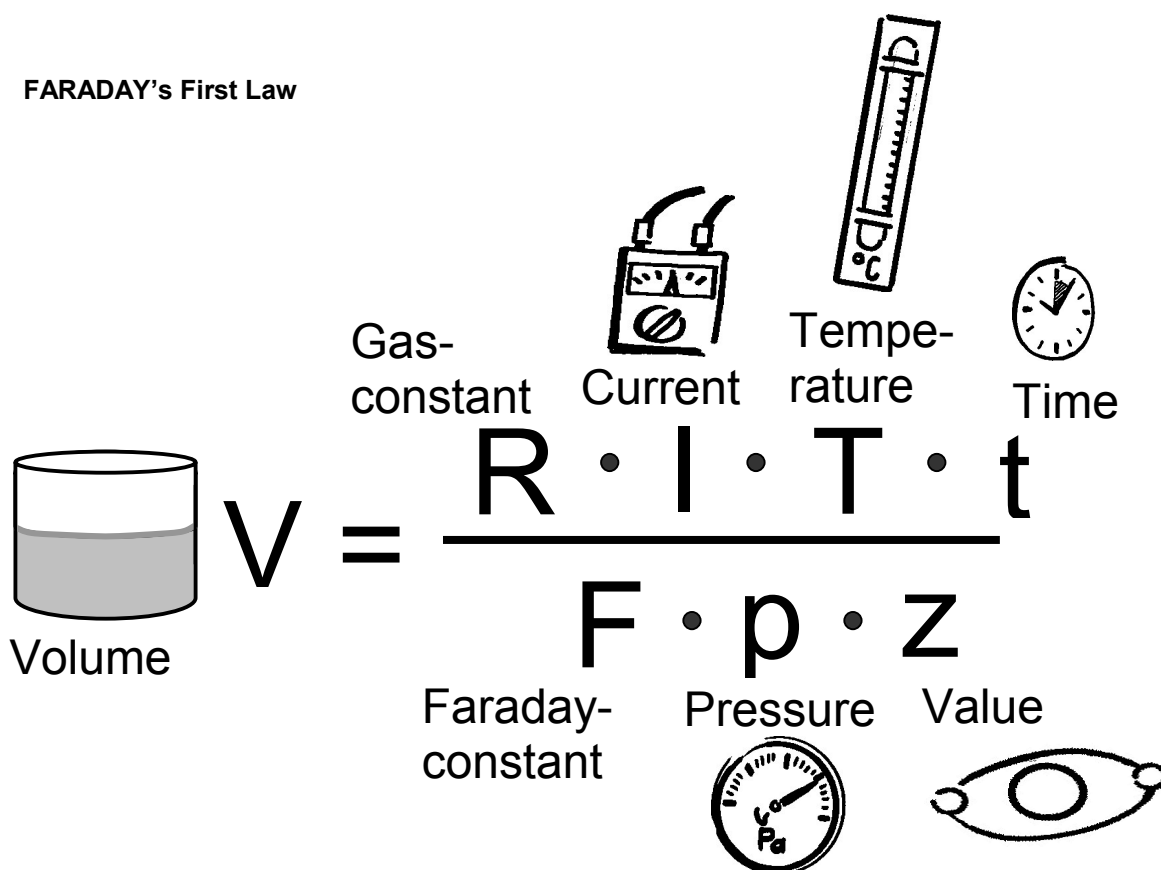

$$V = \frac{R \cdot I \cdot T \cdot t}{F \cdot p \cdot z}$$

Volume

Gas-constant

Current

Temperature

Time

Faraday-constant

Pressure

Value

V = Volume of gas produced in m^3

R = Universal gas constant = $8,314 \text{ J}/(\text{mol K})$

T = Ambient temperature

I = Current in A

t = Time in s

p = Ambient pressure

F = Faraday's constant = $96485 \text{ C}/\text{mol}$

z = Number of 'excess' electrons (e.g. $z(\text{H}_2)=2$, $z(\text{O}_2)=4$)

Faraday's efficiency can now be obtained from:

$$\eta_{\text{Faraday}} = \frac{V_{\text{H}_2} \text{ (produced in experiment)}}{V_{\text{H}_2} \text{ (calculated from theory)}}$$

Experimental setup and procedures:

1.

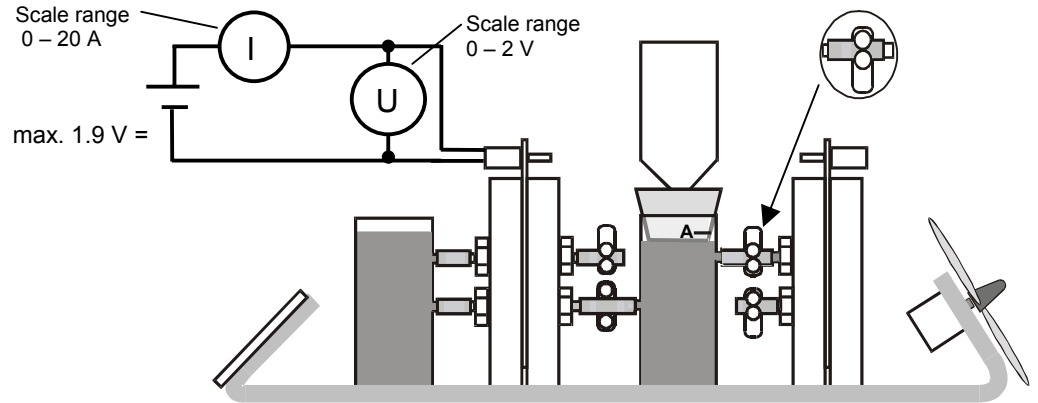

2.

The electrolyzer should be operated for about 10 minutes at a constant current of 1 A¹⁾ and a voltage under 1.9 V before measurements are taken.

3.

Turn off current
&

fill the empty gas storage tank
with distilled water to level A.

**! Note: Remember to put expansion
tank back in place !**

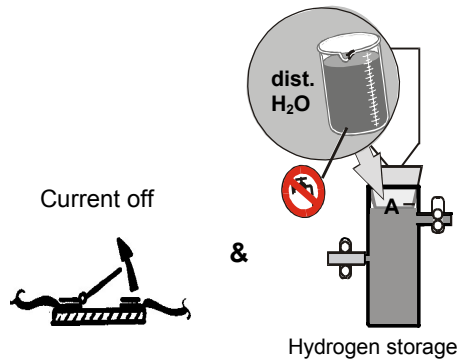

4.

Turn on current (1A)
&

start measuring the time.

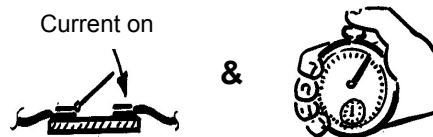

¹⁾ If you use a constant current there will be a direct proportionality in Faraday's first law.

5.

The easiest procedure is to measure time, current and voltage at regular volume steps (e.g. 5 cm³).

6.

Table 5 contains example results:

| V _{H₂} / cm ³ | t / s | U / V | I / A |
|--|-------|-------|-------|
| 0 | 0 | - | - |
| 5 | 40 | 1,9 | 1 |
| 10 | 73 | 1,9 | 1 |
| 15 | 114 | 1,9 | 1 |
| 20 | 157 | 1,9 | 1 |
| 25 | 198 | 1,9 | 1 |
| 30 | 235 | 1,9 | 1 |
| 35 | 276 | 1,9 | 1 |
| 40 | 332 | 1,9 | 1 |

Table 5

$$\bar{P} = \bar{U} \cdot \bar{I} \approx 1,9 \text{ W}$$

$$\eta_{\text{Faraday}} = \frac{V_{\text{H}_2} \text{ (experimental)}}{V_{\text{H}_2} \text{ (theoretical)}}$$

$$V_{\text{H}_2} \text{ (experimental)} = 40 \text{ cm}^3$$

$$V_{\text{H}_2} \text{ (theoretical)} = \frac{(8,314 \text{ J / mol} \cdot \text{K}) \cdot 298 \text{ K} \cdot 1 \text{ A} \cdot 332 \text{ s}}{1,013 \cdot 10^5 \text{ Pa} \cdot (96485 \text{ C / mol}) \cdot 2} \approx 42 \text{ cm}^3$$

$$\eta_{\text{Faraday}} = \frac{40 \text{ cm}^3}{42 \text{ cm}^3} \approx 0,95$$

A portion of the produced gases reacts to water without leaving the cell and is therefore lost.

The energy efficiency can be determined from the ratio of usable energy and energy expended, i.e. the heat energy stored in the produced hydrogen and the electric energy spent in producing it.

The usable energy is given by the calorific value of the total amount of hydrogen and the expended energy is given by the electric energy spent in producing the hydrogen.

$$\eta_{\text{energetic}} = \frac{E_{\text{hydrogen}}}{E_{\text{electric}}} = \frac{V_{\text{H}_2} \cdot H_o}{U \cdot I \cdot t} = \frac{40 \cdot 10^{-6} \text{ m}^3 \cdot (12745 \cdot 10^3 \text{ J/m}^3)}{1,9 \text{ V} \cdot 1 \text{ A} \cdot 332 \text{ s}} \approx 0,81$$

V_{H₂} = Experimental produced volume of H₂ in m³

H_o = Gross calorific value ¹⁾ = 12745 kJ/m³

U = Voltage in V

I = Current in A

t = Time in s

¹⁾ The gross calorific value includes the total energy stored in the hydrogen (including the condensation energy in the water vapor). The net calorific value H_n=10,800 kJ/m³ is more commonly used because it allows a direct comparison of combustion engines and fuel cells.

11. Using the hydrogen in the fuel cell

As with the electrolyzer, the current-voltage characteristic and the efficiency can be determined with the fuel cell as well.

11.1. Current-voltage characteristic of the fuel cell

Experimental setup and procedures:

1.
For visual clarity the electric fan may be connected in parallel with the resistors.

Note that the fan's resistance depends on its rpm. Therefore, you may not be able to easily determine the combined resistance of resistor and fan.

2.
Open the fuel cell's bottom clamp.

3.
Turn on the current.
When the fan starts to rotate (or when no more water leaves the fuel cell) then close the fuel cell's bottom clamp.

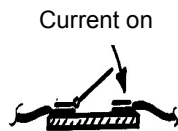
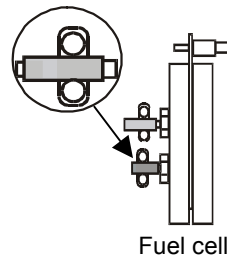
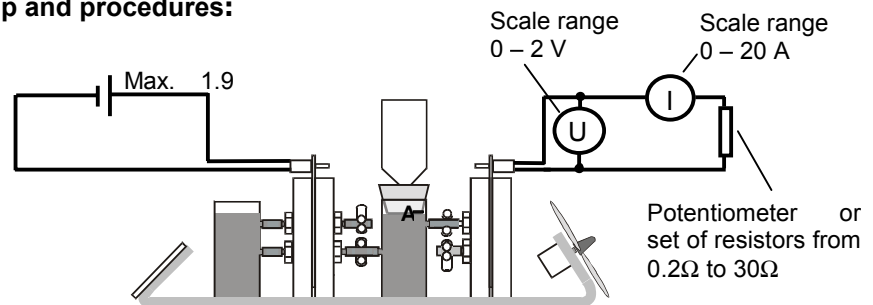

When
the fan starts to rotate
(or when no more
water leaves the fuel cell)

**This ensures that
hydrogen is stored.**

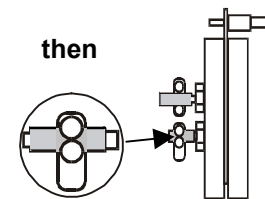

4.

For the current-voltage characteristic begin with the no-load voltage and vary the resistor from large to small.

The resistors can be between 0.1Ω and 330Ω . However, using resistances between 0.5Ω and 30Ω is sufficient.

Wait for a few seconds to allow a reliable reading.

! Warning: The short circuit current must not exceed 10 seconds or else the cell might be destroyed !

5.

Table 6 contains some example results:

| | | | | | | | | | | |
|---------------|----------|------|------|------|------|------|------|------|------|------|
| R in Ω | ∞ | 22 | 5,6 | 2,7 | 1,8 | 1 | 0,68 | 0,33 | 0,22 | 0 |
| U in V | 0,91 | 0,81 | 0,74 | 0,67 | 0,61 | 0,48 | 0,34 | 0,22 | 0,17 | 0,03 |
| I in A | 0 | 0,03 | 0,12 | 0,24 | 0,33 | 0,48 | 0,54 | 0,57 | 0,59 | 0,61 |

Table 6

Current-voltage characteristic of the fuel cell

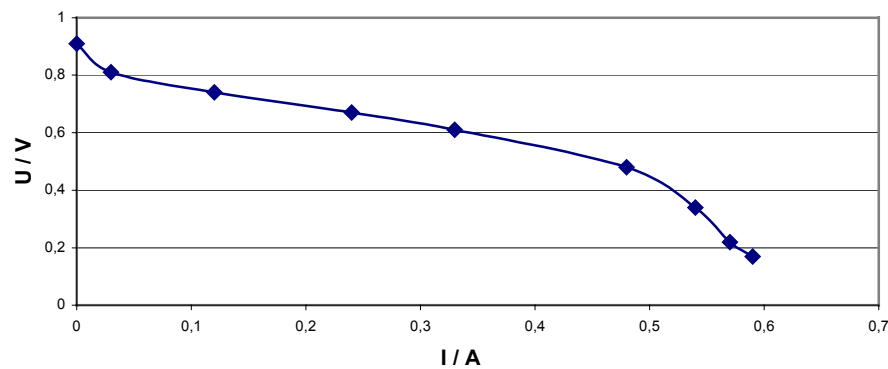

Power characteristic of the fuel cell

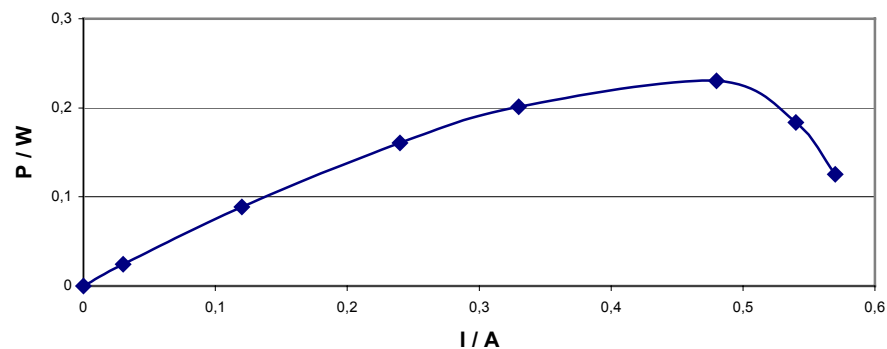

11.2. Faraday's first law and fuel cell efficiency

Similar to the procedures described in section 10.2. for the electrolyzer efficiency, we can use Faraday's first law to obtain the fuel cell efficiency.

Here we use Faraday's first law to calculate the theoretical consumption of the cell. Faraday's efficiency can now be obtained by taking the ratio of actual consumption and theoretically calculated consumption.

$$V = \frac{R \cdot I \cdot T \cdot t}{F \cdot p \cdot z}$$

V = Volume of gas consumption in m³

R = Universal gas constant = 8,314 J/(mol K)

T = Ambient temperature

I = Current in A

t = Time in s

p = Ambient pressure

F = Faraday's constant = 96485 C/mol

z = Number of 'excess' electrons

(e.g. z(H₂)=2, z(O₂)=4)

$$\eta_{\text{Faraday}} = \frac{V_{\text{H}_2} \text{ (calculated from theory)}}{V_{\text{H}_2} \text{ (consumed in experiment)}}$$

Experimental setup and procedures:

1.

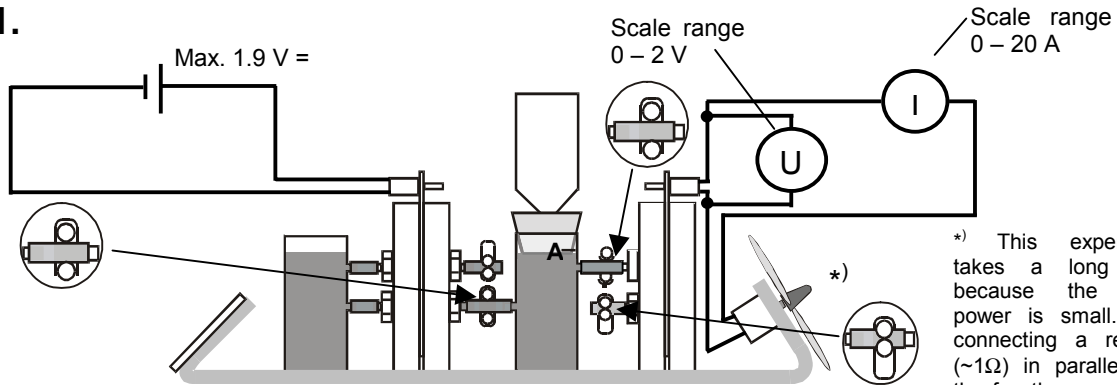

2.

Open the fuel cell's bottom clamp.

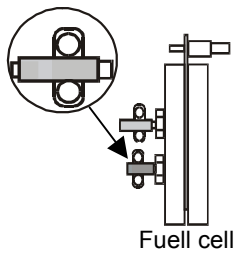

3.

Turn on the current.

When
the fan starts to rotate
(or when no more water
leaves the fuel cell)

then
close the fuel cell's
bottom clamp.

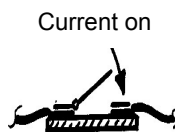

When
the fan starts to rotate
(or when no more
water leaves the fuel cell)

**This ensures that
hydrogen is stored.**

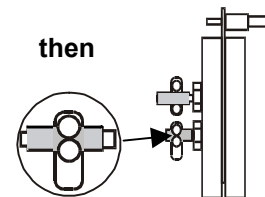

4.

Disconnect the fan
&
wait
until

hydrogen storage tank is
filled (approx. 5 minutes).

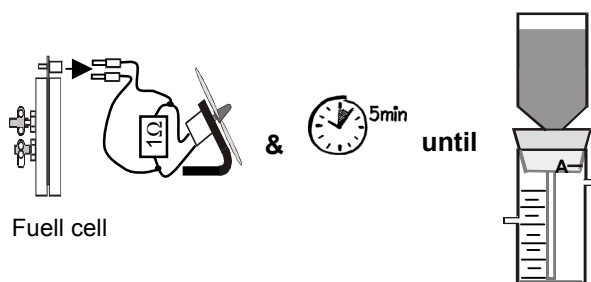

5.

Turn off current
&
close the electrolyzer's
bottom clamp.

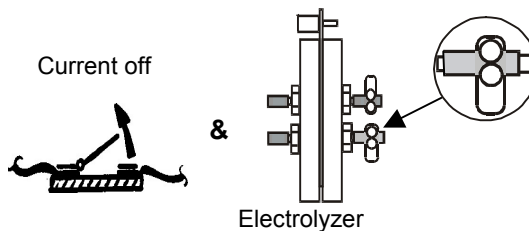

6.
 Open the fuel cell's bottom clamp briefly until the water reaches a level of 30 cm³.

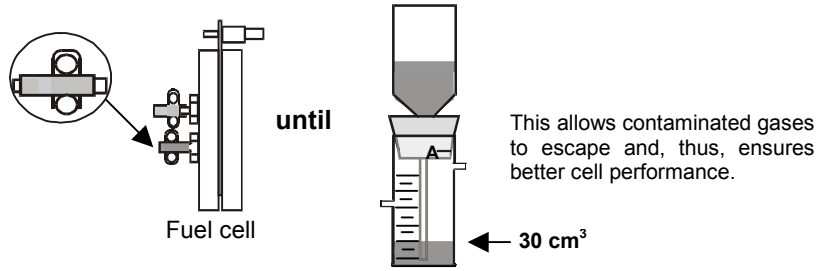

Then close the fuel cell's bottom clamp.

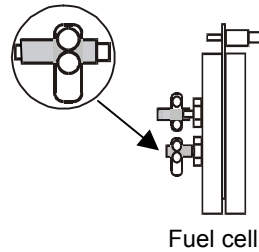

7.
 Connect the fan, then start taking the time & measure current, voltage and volume.

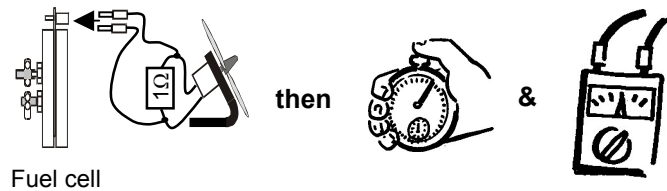

8.
 We recommend that current, voltage and elapsed time are measured at constant volume intervals (e.g. 5 cm³).

9.
 Example results: (R = 5,6 Ω)

| Consumption H ₂ / cm ³ | t in s | U / V | I / A |
|--|--------|-------|-------|
| 0 | 0 | - | - |
| 5 | 375 | 0,74 | 0,1 |
| 10 | 750 | 0,74 | 0,1 |
| 15 | 1125 | 0,73 | 0,1 |
| 20 | 1500 | 0,73 | 0,1 |
| 25 | 1875 | 0,72 | 0,1 |

Table 7

$$\bar{P} = \bar{U} \cdot \bar{I} \approx 0,07 \text{ W}$$

$$\eta_{\text{Faraday}} = \frac{V_{\text{H}_2} \text{ (calculated consumption)}}{V_{\text{H}_2} \text{ (real consumption)}}$$

$$V_{\text{H}_2} \text{ (calculated)} = \frac{(8,314 \text{ J/mol}\cdot\text{K}) \cdot 297 \text{ K} \cdot 0,1 \text{ A} \cdot 1875 \text{ s}}{1,013 \cdot 10^5 \text{ Pa} \cdot (96485 \text{ C/mol}) \cdot 2} \approx 24 \text{ cm}^3$$

$$V_{\text{H}_2} \text{ (consumed)} = 25 \text{ cm}^3$$

$$\eta_{\text{Faraday}} = \frac{24 \text{ cm}^3}{25 \text{ cm}^3} \approx 0,96$$

The volume of gas used in the experiment is somewhat larger than the theoretically determined volume because of diffusion processes inside the fuel cell (similar to the electrolyzer).

$$\eta_{\text{energetic}} = \frac{E_{\text{electric}}}{E_{\text{hydrogen}}} = \frac{U \cdot I \cdot t}{V_{\text{H}_2} \cdot H_u} = \frac{0,72 \text{ V} \cdot 0,1 \text{ A} \cdot 1875 \text{ s}}{25 \cdot 10^{-6} \text{ m}^3 \cdot 10800 \cdot 10^3 \text{ J/m}^3} = 0,5$$

V_{H_2} = Consumed volume of H_2 in m^3

H_u = Net calorific of hydrogen ¹⁾ = 10800 kJ/m³

U = Voltage in V

I = Current in A

t = Time in s

The fuel cell's efficiency (like the electrolyzer's efficiency) depends strongly on the power. The closer the electrical load is to the maximum available power of the fuel cell, the higher the efficiency will be, although the fuel cell will run at a portion of its total potential power

¹⁾ The net and gross calorific values of hydrogen differ by the condensation energy. This form of energy can only be used as heat, not as electric energy.

12. Foils

- 12.1. To get an idea of the size of an oil field
- 12.2. Principles of solar hydrogen technology
- 12.3. Solar cell
- 12.4. PEM-Electrolyzer and PEM-Fuel cell
- 12.5. Comparison: Traditional energy system with hydrogen energy system

To get an idea of the size of an oil field

Source:
Sueddeutsche Zeitung, Dec 10, 1997
(Southern German News)

Oil company Elf discovers huge oil reservoir off Angolan coast

Paris (AFP) – The French oil company Elf Aquitaine has discovered another huge oil field off the West African coast. It is located 200 km from Luanda, Angola's capital. The size of this new field is estimated to be 730 million barrels. **This makes it one of the largest findings in recent years.** The new oil field is located very close to two other large reservoirs that have been previously discovered by Elf Aquitaine. Their sizes are estimated to be 660 and approximately 700 million barrels.

Based on today's rate of oil consumption this reservoir can provide us with oil for **ten days!**

Principles of solar hydrogen technology

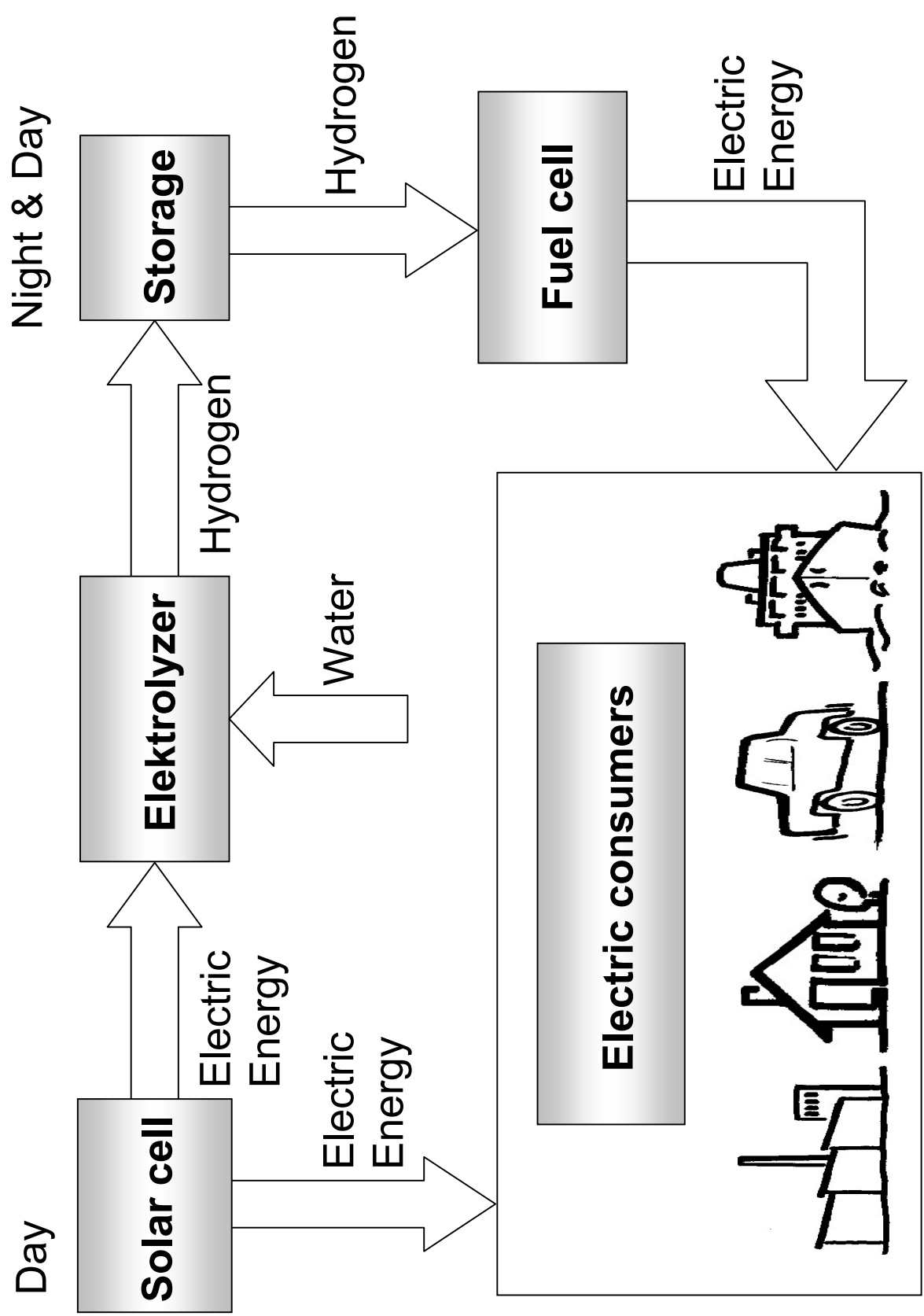

Solar cell
(not to scale)

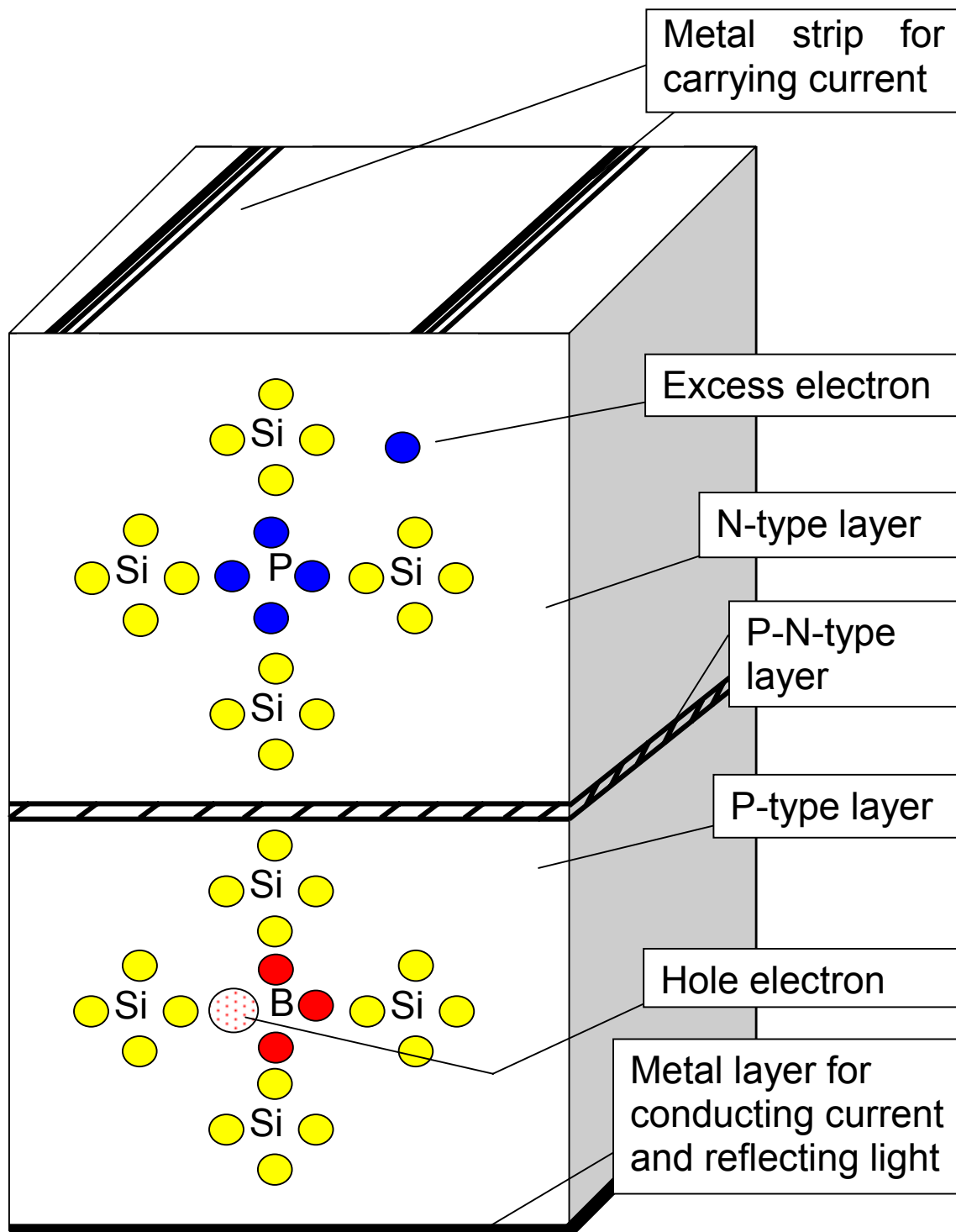

PEM Electrolyzer

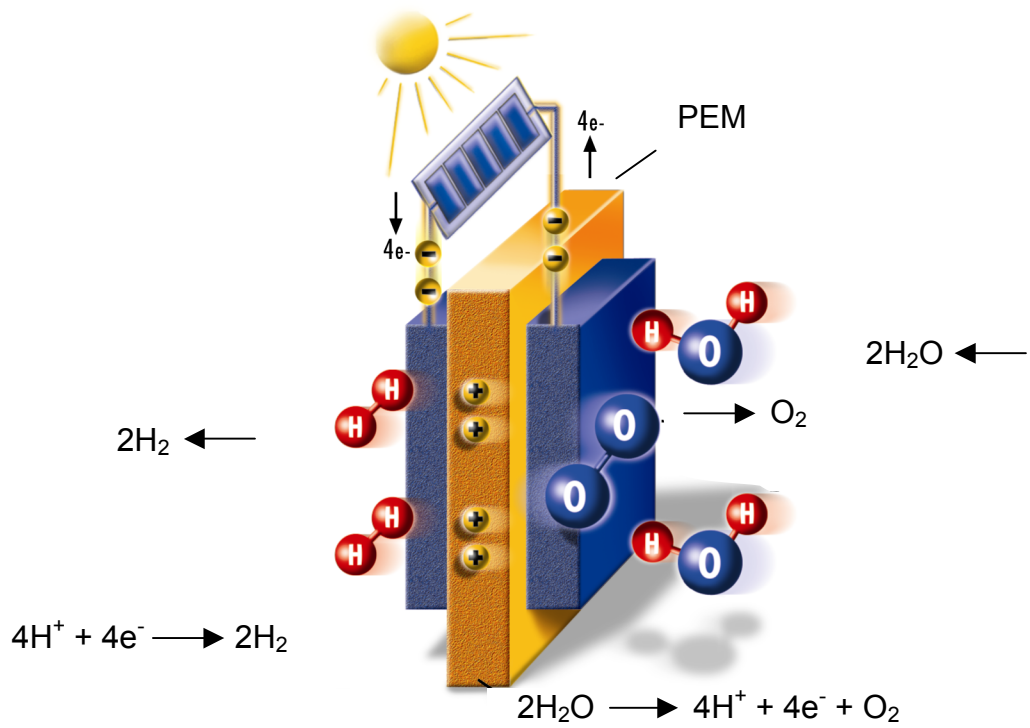

PEM Fuel cell

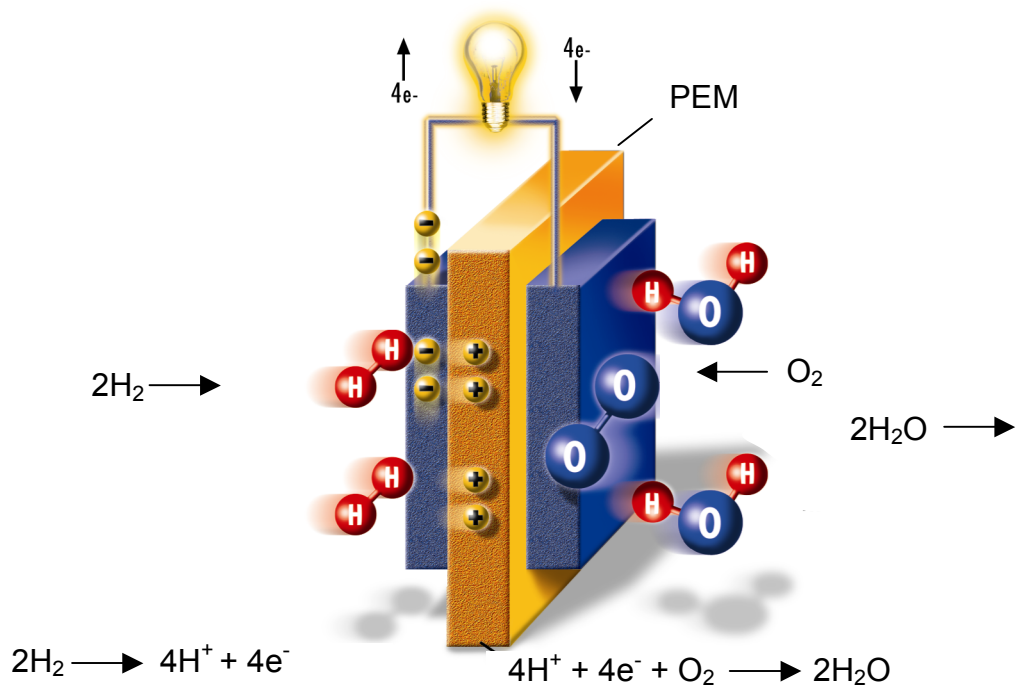

Energy system based on fossil fuel

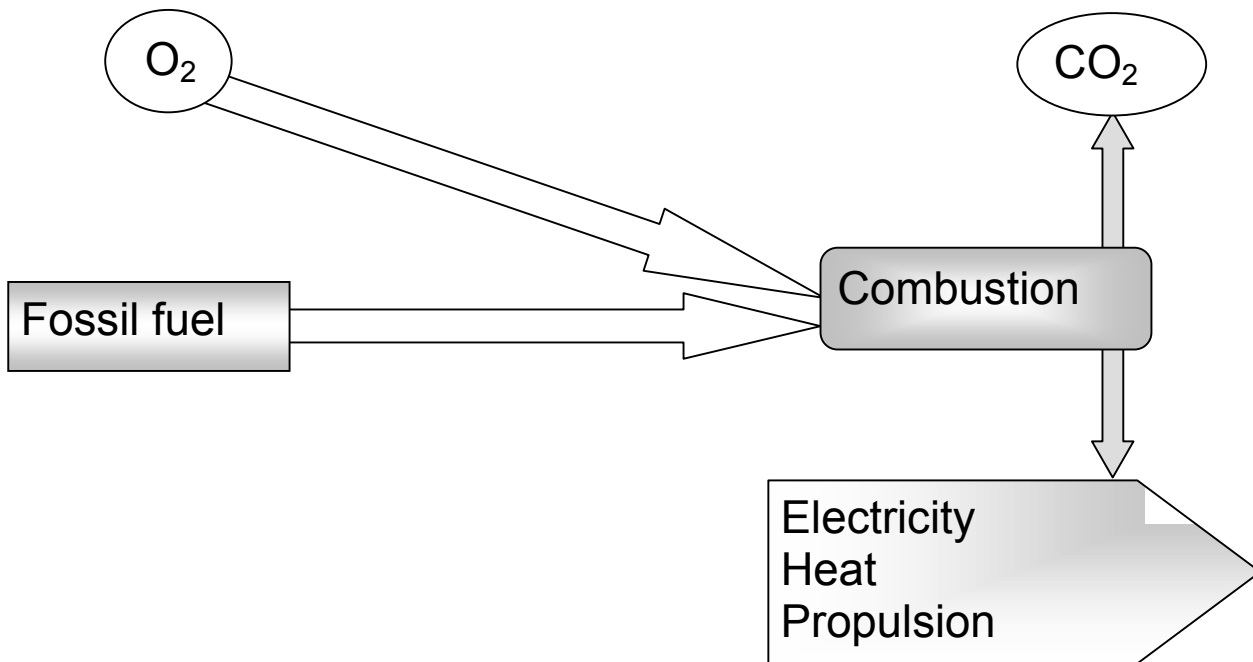

Energy system based on hydrogen

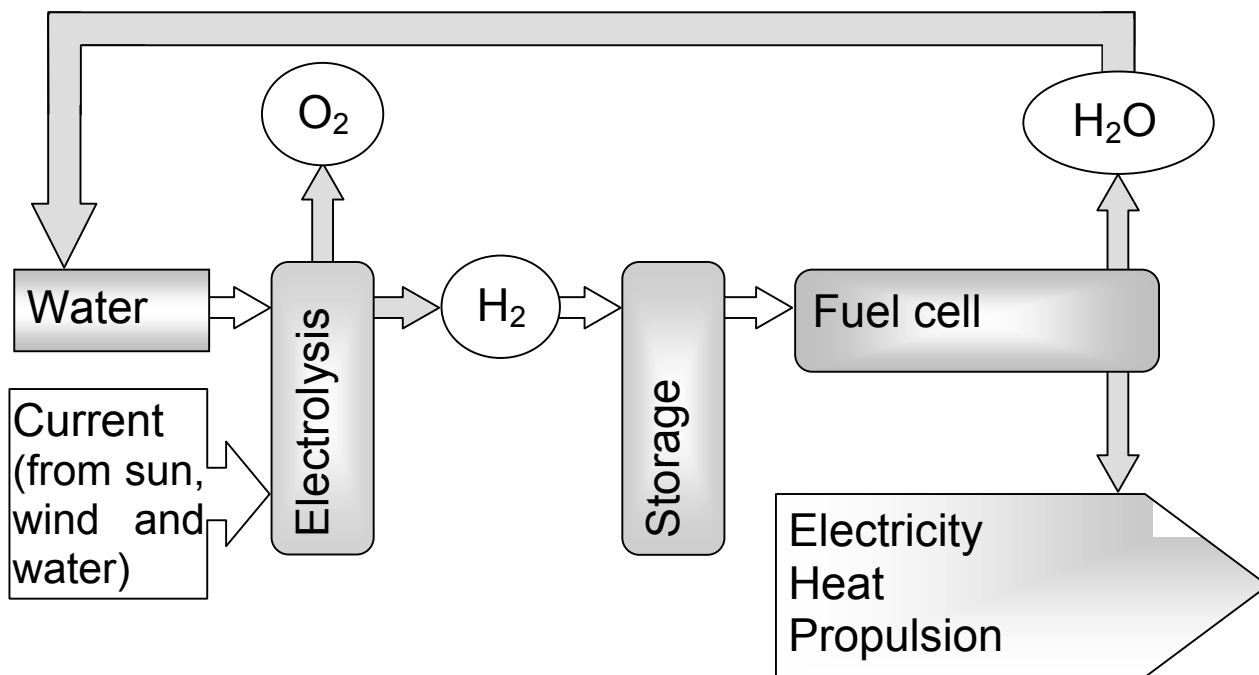

13. Experiments for students

13.1. Photoelectric current and no-load voltage as a function of distance and angle of incidence between solar cell and light source

1.
Set up the experiment according to the diagram below.

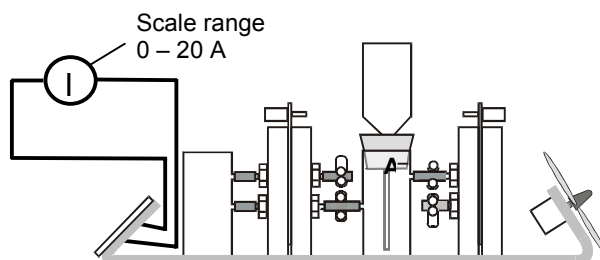

2.
Place the light more than 40 cm from the solar cell and measure the current.

! This distance is only valid for H-TEC lamp "Videolight" (Art.-No.: 1931) !

3.
Vary the distance between the light and the solar cell (e.g. in steps of 20 cm) and record the corresponding currents in the table below.

4.
Plot the data and analyze your results.

| | | | | | | | | | | |
|----------------|--|--|--|--|--|--|--|--|--|--|
| Distance in cm | | | | | | | | | | |
| Current in A | | | | | | | | | | |

5.
Move the light along a semi-circle (Radius more than 40 cm) around the solar cell. Measure both current and the angle between your starting point and the new location of your light. Record your results in the table

| | | | | | | | | | | |
|--------------|--|--|--|--|--|--|--|--|--|--|
| Angle in ° | | | | | | | | | | |
| Current in A | | | | | | | | | | |

6.
Plot your data and analyze.

7.
Now repeat the experiments for the no-load voltage.
Set the scale range of your voltmeter to 0-20 V.

| | | | | | | | | | | |
|----------------|--|--|--|--|--|--|--|--|--|--|
| Distance in cm | | | | | | | | | | |
| Voltage in V | | | | | | | | | | |
| Angle in ° | | | | | | | | | | |
| Voltage in V | | | | | | | | | | |

8.
Plot your data and analyze.

13.2. Current-voltage characteristic of the solar cell

- 1.**
Set up the experiment according to the diagram below.

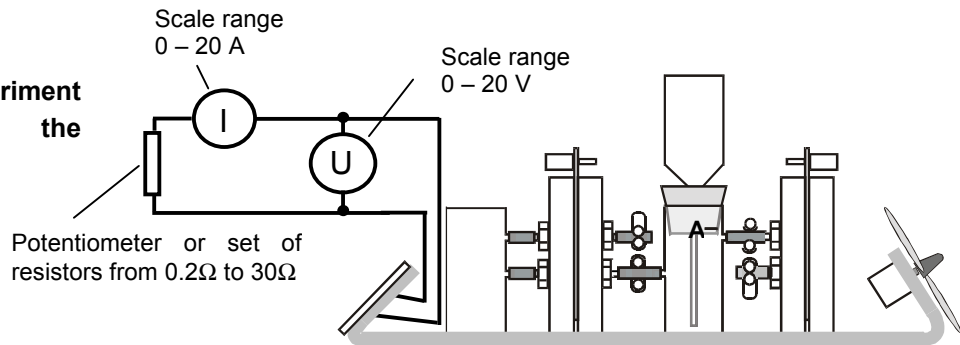

- 2.**
Before taking your measurements the solar cell should be illuminated for about five minutes. This will allow the cell to heat evenly.

- 3.**
Illuminate the solar cell (place the light more than 40 cm away), exchange the resistors step by step (start with the largest one) and record the corresponding voltages and currents for every resistance value.

| | | | | | | | | | | |
|---------------|--|--|--|--|--|--|--|--|--|--|
| R in Ω | | | | | | | | | | |
| U in V | | | | | | | | | | |
| I in A | | | | | | | | | | |
| | | | | | | | | | | |

- 4.**
The current-voltage characteristic tells you about the solar cell's performance. It allows you to determine the cell's maximum power point (MPP).

- 5.**
Plot the current-voltage as well as the power-voltage characteristic.

13.3. Current-voltage characteristic of the electrolyzer

1.

Set up the experiment according to the diagram below. The voltage should be adjustable between 0 and 1.9 V.

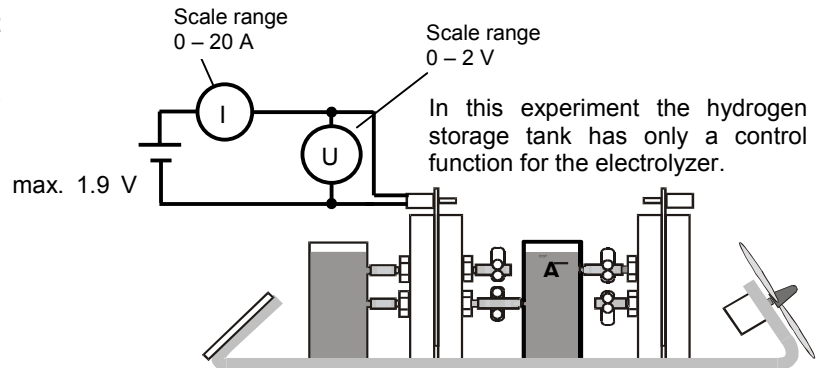

2.

Allow the electrolyzer to operate for about one minute at a voltage of 1.8 V.

3.

Disconnect the electrolyzer's positive and negative pole from the power supply and connect the two poles for one minute.

4.

Increase the voltage in steps from 0 to 1.9 V and record the corresponding currents.

Note: you will probably not be able to measure anything for $U=0$ V.

Start with the lowest value where your current meter allows a good reading.

| | | | | | | | | | | | | | | | | | | | |
|--------|--|--|--|--|--|--|--|--|--|--|--|--|--|--|--|--|--|--|--|
| U in V | | | | | | | | | | | | | | | | | | | |
| I in A | | | | | | | | | | | | | | | | | | | |

5.

Plot the electrolyzer's I-U characteristic and analyze it.

13.4. Faraday's first law and electrolyzer efficiency

Set up the experiment as follow:

1.

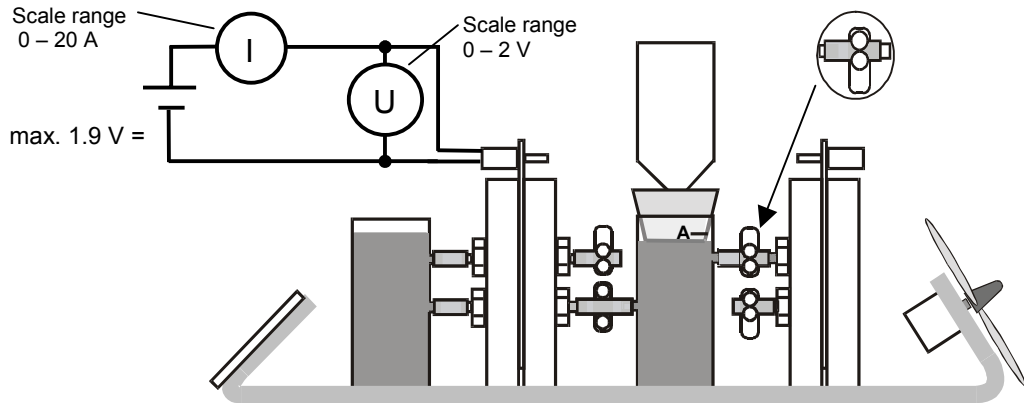

2.

The electrolyzer should be operated for about 10 minutes at a constant current of 1A and at a voltage of less than 1.8V before measurements are taken.

3.

Turn off current
&

empty gas storage tank and fill with distilled water to level A.

Note: Remember to put the expansion tank back in place!

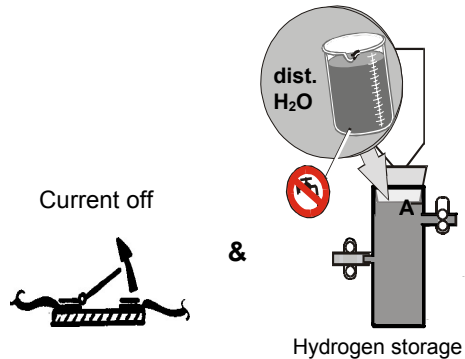

4.

Turn on current (1Ampere)

&

start measuring the time.

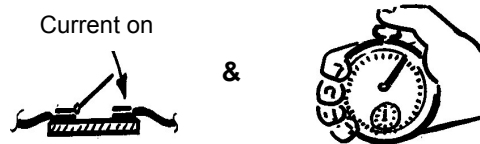

5.

At constant volume steps (e.g. 5 cm³), report the elapsed time, the current and the voltage in this table.

| | | | | | | | | | |
|--|--|--|--|--|--|--|--|--|--|
| Produced volume of H ₂ in cm ³ | | | | | | | | | |
| t in min | | | | | | | | | |
| t in s | | | | | | | | | |
| U in V | | | | | | | | | |
| I in A | | | | | | | | | |

6.

Calculate the electrolyzer's power and the theoretically produced hydrogen volume. You can now obtain Faraday's efficiency by taking the ratio of the produced volume and the calculated volume.

The power is the product of the average results of current and voltage.

You get the theoretically produced volume with following formula:

$$V = \frac{R \cdot I \cdot T \cdot t}{F \cdot p \cdot z}$$

V = Volume of gas theoretically produced in m³

R = Universal gas constant = 8,314 J/(mol K)

T = Ambient temperature in K

I = Current in A

t = Time in s

p = Ambient pressure in Pa

F = Faraday's constant = 96485 C/mol

z = Number of 'excess' electrons

(e.g. z(H₂)=2, z(O₂)=4)

13.5. Current-voltage characteristic of the fuel cell

1. Set up the experiment as follows:

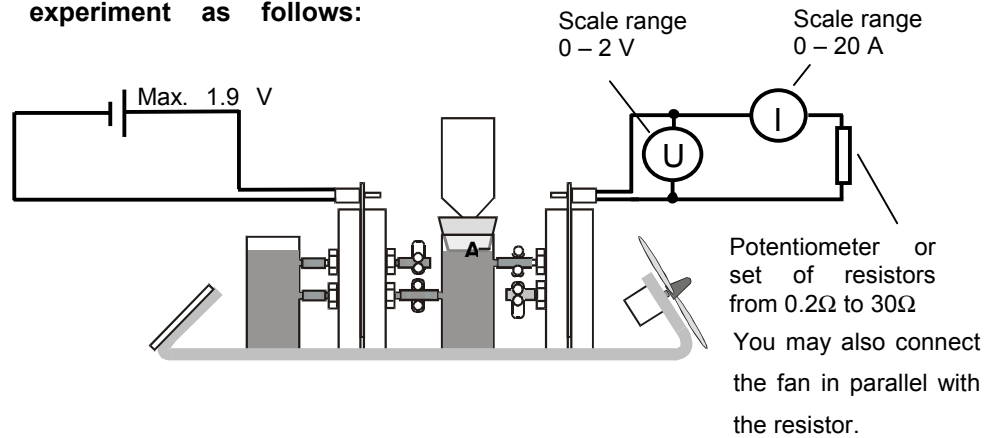

2. Open the fuel cell's bottom clamp.

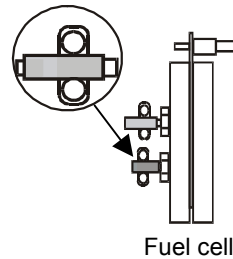

3. Turn on the current.
When
 the fan starts to rotate
 (or when no more water leaves the fuel cell)
then
 close the fuel cell's bottom clamp.

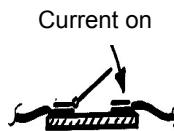

When
 the fan starts to rotate
 (or when no more water leaves the fuel cell)

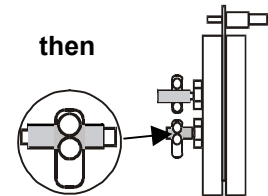

This ensures that hydrogen is stored.

4. Vary the resistance from large to small. For every resistance, wait for a few seconds to allow for a reliable reading. Then measure voltage and current and report your results in this table.

| | | | | | | | | | |
|---------|--|--|--|--|--|--|--|--|--|
| R in Ω | | | | | | | | | |
| U in mV | | | | | | | | | |
| I in mA | | | | | | | | | |
| | | | | | | | | | |

5. Plot the current-voltage characteristic and interpret it. Calculate the fuel cell's power.

13.6. Faraday's first law and fuel cell efficiency

Set up the experiment as explained in points 1-7 of the experiment 11.2.

8.

At constant volume intervals, report voltage, current and elapsed time in the table below.

| Consumption H_2 / cm^3 | t in min | t in s | U / V | I / A |
|----------------------------|----------|--------|-------|-------|
| | | | | |
| | | | | |
| | | | | |
| | | | | |
| | | | | |
| | | | | |
| | | | | |

9.

Calculate the cell power and the theoretical consumption.

The Faraday efficiency is then given by the ratio of actual and theoretical consumption.

The power is the product from the average results of current and voltage.

14. CONTACT:

If you have any questions or require further information please contact us:

H-TEC
Wasserstoff-Energie-Systeme GmbH
Lindenstraße 48a
23558 LUEBECK
GERMANY
Tel.: (+49 – 451) 879 1213
Fax.: (+49 – 451) 879 1215

e-mail : info@h-tec.com

website : www.h-tec.com